

**Biology and Human Behavior:
The Neurological Origins of Individuality
2nd Edition
Part I
Professor Robert Sapolsky**



THE TEACHING COMPANY ®

Robert Sapolsky, Ph.D.

Professor of Neurology and Neurosurgery, Stanford University

Robert Sapolsky holds the John A. and Cynthia Fry Gunn Professorship of Biological Sciences at Stanford University, where he is also professor of Neurology and Neurosurgery. His laboratory focuses on the mechanisms by which stress and stress hormones can damage the brain and on the development of gene therapy strategies to save neurons from neurological insults. In addition, Professor Sapolsky has spent his summers since the late 1970s studying a population of wild baboons in East Africa, examining what social rank, personality, and patterns of sociality have to do with vulnerability to stress-related diseases.

Professor Sapolsky writes regularly for nonscientists in such publications as *Scientific American*, *Discover*, *Natural History*, and *The New Yorker*. He is also the author of five books, including four nontechnical publications for the general public: *Why Zebras Don't Get Ulcers: A Guide to Stress, Stress-Related Diseases and Coping*, 3rd edition (2004, Henry Holt); *The Trouble with Testosterone and Other Essays on the Biology of the Human Predicament* (Scribner, 1997); *A Primate's Memoir* (Scribner, 2001); and *Monkeyluv and Other Essays on Our Lives as Animals* (Scribner, 2005).

Table of Contents
Biology and Human Behavior:
The Neurological Origins of Individuality
2nd Edition
Part I

Professor Biography	i
Course Scope	1
Lecture One	Biology and Behavior—An Introduction3
	Module I: The Neurobiology of Behavior at the Cellular Level
Lecture Two	The Basic Cells of the Nervous System.....8
Lecture Three	How Two Neurons Communicate11
Lecture Four	Learning and Synaptic Plasticity15
	Module II: The Neurobiology of Behavior at the Systems Level
Lecture Five	The Dynamics of Interacting Neurons.....20
Lecture Six	The Limbic System.....26
Lecture Seven	The Autonomic Nervous System (ANS)32
	Module III: The Neuroendocrinology of Behavior
Lecture Eight	The Regulation of Hormones by the Brain37
Lecture Nine	The Regulation of the Brain by Hormones41
	Module IV: Evolution and the Neurobiology of Behavior
Lecture Ten	The Evolution of Behavior45
Lecture Eleven	The Evolution of Behavior—Some Examples.....48
Lecture Twelve	Cooperation, Competition, and Neuroeconomics51
Glossary	55
Biographical Notes	Part II
Bibliography	Part II

Biology and Human Behavior: The Neurological Origins of Individuality 2nd Edition

Scope:

From time immemorial, the more philosophical among us have pondered: “What is the essence of who I am? What is it that has made me who I am?” Behavioral biology is the science of trying to figure this out, with the guiding assumption that an understanding of who and why we are cannot be achieved without considering our biology.

Now, a human asking these sorts of questions is more complicated, for a myriad of reasons, than a wildebeest asking, “Why is it in my essence to ovulate during one short period of time each year?” or a migratory bird wondering, “Why is it that each year I wish to fly from Tierra del Fuego to Alaska?” Tackling the biology of behavior is particularly daunting when considering humans and their social behaviors.

These challenges are even more extreme when considering an aspect of our behavior that is often the most interesting and important to study: What is the behavioral biology of our *abnormal* human behaviors? Because of the intrinsic intellectual challenge of a subject such as this, and because of its implication, when we ask a question about the biology of abnormal human behavior, we are often, de facto, asking: Whose *fault* is it that this has occurred; who should be held *accountable*? Multiple murderer: damaged frontal cortex or tainted soul? Spouse unable to get out of bed or go to work: victim of the neurochemistry of depression or self-indulgent slacker? Child failing at school: learning disabled or lazy?

This course is an introduction to the biology of human behavior, often of abnormal human behavior, with an emphasis on the brain. The purpose of the course is twofold: first, to teach the contemporary science of how our brains regulate our thoughts, emotions, and feelings—how our brains make us the individuals that we are—and second, to teach how our brains are regulated—sculpted by evolution, constrained or freed by genes, shaped by early experience, modulated by hormones. In this framework, the view is not of the brain as the be-all and end-all of what makes us individuals but, rather, the brain as the final common pathway, the conduit by which our individuality is shaped by biology that started anywhere from seconds to millions of years ago.

After an introductory lecture presenting this framework, a quarter of the course (Modules I and II) will be devoted to the functions of the nervous system. These lectures are updated versions of those in the first edition of this Teaching Company course and will start at the level of how a single neuron functions, building upward until we examine how millions of neurons in a particular region of the brain operate. The focus will be on the regions of the brain most pertinent to emotion and behavior, rather than, say, to regulation of kidney function.

The middle portion of the course (Modules III, IV, and V) will explore how the brain and behavior are regulated. First, we will cover how the brain regulates hormones and how hormones influence brain function and behavior. Then, we will examine how both the brain and behavior evolved, covering contemporary thinking about how natural selection has sculpted and optimized behavior and how that optimization is mediated by brain function. We will then focus on a bridge between evolution and the brain, namely, what genes at the molecular level have to do with brain function and how those genes have evolved.

Hormones, evolution, genes, and behavior, however, do not work in vacuo but, instead, are extremely sensitive to environment. The next section of the course (Module VI) examines *ethology*, which is the study of the behavior of animals in their natural habitats (rather than, for example, in a laboratory cage).

With these various approaches in hand, the final quarter of the course (Module VII) will examine how each approach helps explain an actual set of behaviors. Among a number of possible topics, we will focus on aggression, both because of the extensive information available and the importance of the subject.

The facts of this subject are not intrinsically difficult, even for the nonscientist. The implications, however, should seem far from simple. Yet this is a subject that each of us must master, because all of us are, de facto, behavioral biologists. We serve on juries, deciding whom to incarcerate, whom to put to death. We vote for elected officials who have stances regarding gun control and whether violence is inevitable, who determine whether certain types of love between consenting adults should be consecrated by the government imprimatur of marriage, who help decide whether a certain social problem can be fixed by government expenditures or is biologically irrevocable. And many

of us will have to be behavioral biologists when confronting loved ones whose behaviors have changed them to an unrecognizable extent and deciding whether it is “them” or “their disease.”

The final lecture of this course will consider issues such as these: What are the societal and philosophical consequences of knowledge about the biology of our behaviors, the biology of what makes us the individuals that we are?

Lecture One

Biology and Behavior—An Introduction

Scope: The purpose of this course is to explain the biology of what makes us who we are, the biology of our individual differences, the biology of our behaviors. This introductory lecture presents the framework of the course: that there is a neurobiology of who we are, that it is vital to learn about it, and that it can best be understood with the interdisciplinary approach of this course. Throughout the subsequent sections, the constant themes will be the interactions of the various disciplines in their effects upon the brain and how all this helps us to understand individual behavioral differences.

Outline

- I. Biology must be considered as a possible factor in human behavior and individuality.
 - A. Examples of changes of behavior in two adult males illustrate this factor.
 1. Chuck has always been an extrovert—charismatic, confident, and flirtatious. Recently, though, he has been getting more introverted and more withdrawn.
 2. Arthur, on the other hand, has always been obsessive, rigidly ethical, and extremely reliable at work. But recently, he has started to tell inappropriate sexual jokes, and he has even taken to stalking women.
 - B. Could such changes of behavior, often explained as a midlife crisis, actually be the result of a mutation in a single gene? In these two cases, the answer is yes.
 - C. There is a biology to our sexual choices, the extent and type of our religiosity, and everything else about us.
- II. How do we tend to approach the challenge of understanding our behavior?
 - A. Typically, we think categorically, as with colors, coming up with labels and explanations, but categorical thinking has its advantages and its limits. (Figure 1a)
 1. Categorical thinking helps our memory.
 2. But categorical boundaries distort our ability to see the differences and similarities between two different facts.
 3. If you pay too much attention to the boundaries, you have trouble seeing the big picture.
 - B. This course's goal of noncategorical thinking about behavior is critical. Little can be explained by merely thinking about genes alone, or brain chemicals, or hormones, or early experience, or any other single factor.
 - C. Our blueprint for the entire course is to start off looking at what a behavior is in a particular category and a particular class, then to begin to ask biologically, where did that behavior come from? (Figure 1b)
 1. We start off by studying the brain and the nervous system.
 2. Beginning to work back in time, we then try to understand further the things that modulate the nervous system, such as environmental triggers, hormones, and perinatal and fetal development.
 3. Then working further back, we look at the genetic attributes of the population that an individual comes from.
 4. This approach pushes us all the way back to examine what the pressures are of natural selection that sculpted that species.
 - D. Isn't this approach obvious to everyone? Perhaps it is now, but in the not-too-distant past, many prominent scientists in this field were unable to think of the biology of our behavior in such a subtle way and, thus, often became damaging ideologues.

- III.** What are the special challenges of thinking about the biology of behavior in humans versus behavior in other animals?
- A.** In some ways, humans behave just like any other animal, as with the synchronization of female reproductive cycles.
 - B.** In other ways, humans have a physiology very similar to that of other animals, but they utilize the physiology in unique ways.
 - C.** In still other ways, human behavior is utterly unique in the animal world, as with aspects of human sexual behavior for nonreproductive purposes.
- IV.** The general strategy for this course is to see how behavior can be understood in the context of everything from milliseconds of brain activity to millions of years of evolution.
- A.** We start with how the brain works and how the brain produces behavior.
 - 1.** We first study a single brain cell, a neuron, and then move on to understand how one neuron communicates with another.
 - 2.** We work our way up to large networks of neurons, then to how the nervous system can regulate how all of our cells work.
 - 3.** In the section on neurobiology, we will focus on two themes: first, understanding why one individual's nervous system works differently from another's and, second, understanding how this function can change over time (*plasticity*).
 - B.** The subsequent lectures explore what it is that changes how the nervous system works, whether the environment, hormones, early experience, fetal life, genetics, or evolution.
 - C.** Finally, we approach a set of human behaviors with this set of strategic ideas, focusing on a contentious and important area of human behavior: aggression.

Further Reading:

For the most nuanced and insightful book written concerning the biology of human behavior, by an eminent scientist/physician:

M. Konner, *The Tangled Wing: Biological Constraints on the Human Spirit*.

Questions to Consider:

- 1.** What are the most substantive differences between humans and other animals?
- 2.** What are the most substantive similarities?

Figure 1a

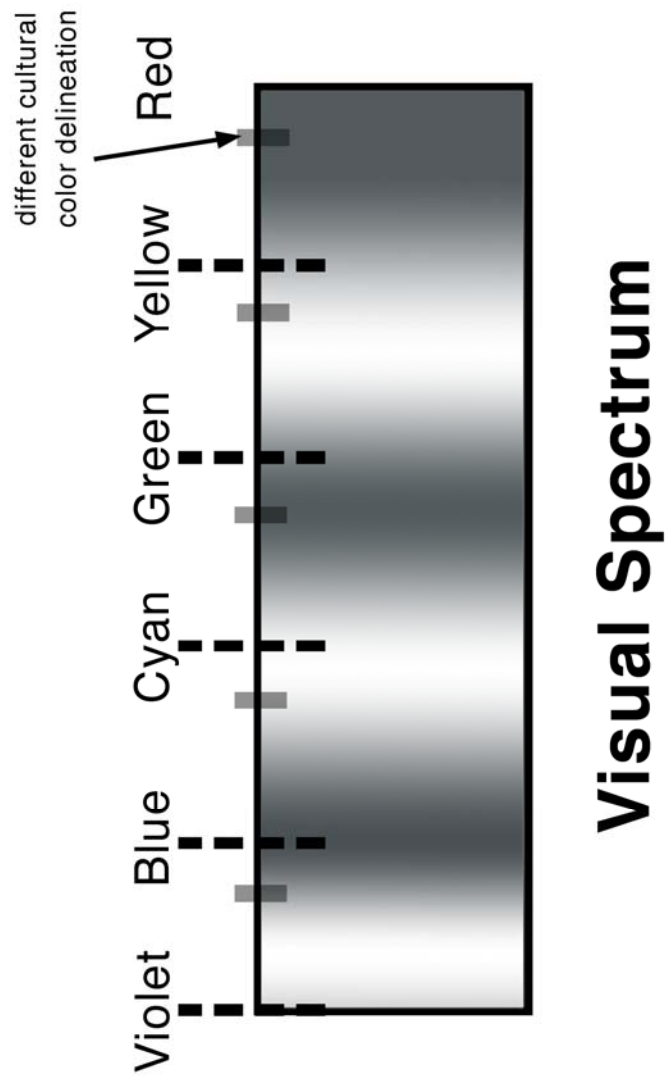

Visual Spectrum

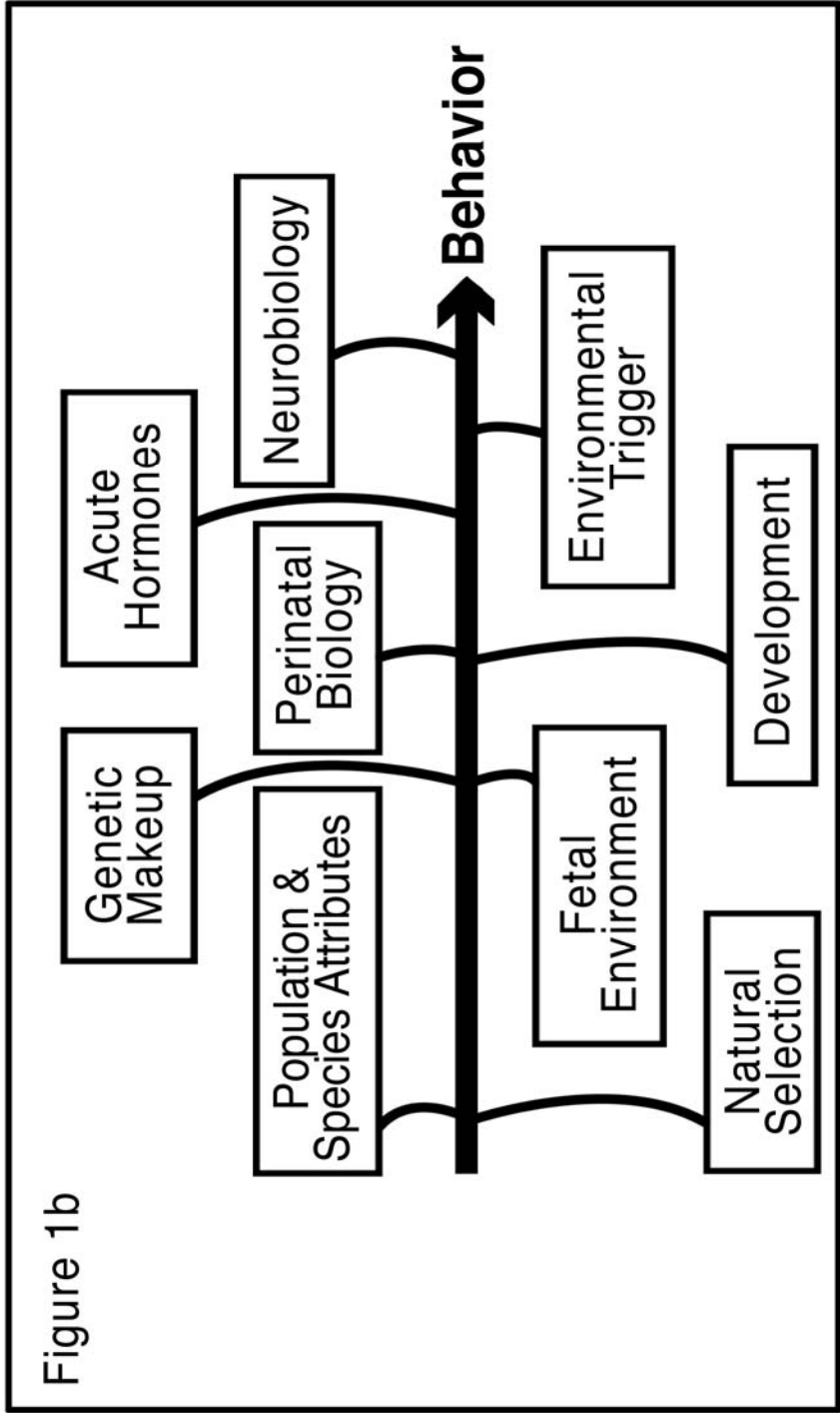

Module I

The Neurobiology of Behavior at the Cellular Level

Module Scope:

This module, which covers the next three lectures, begins with an overview of how a single neuron works. This study will then be expanded to see how two neurons communicate with each other through the use of neurotransmitters—chemical messengers in the brain. Finally, there is an overview of the critical topic of how such intercellular communication can change over time, that is, how the brain, at the level of pairs of neurons, learns and changes in response to the environment.

Lecture Two

The Basic Cells of the Nervous System

Scope: This lecture covers the basic building blocks of neurobiology, beginning with an overview of the neuron, its various parts, and how each part functions and communicates with other neurons. We will come to understand the difference between the quiescent state, or *resting potential*, of neurons and the excited state, or *action potential*, of neurons. We will also go over the two types of brain cells, *neurons* and *glial cells*.

Outline

- I. The basic constituent of the nervous system is the brain cell. (Figure 2a)
 - A. The main brain cell is the *neuron*. The other type of brain cell is the *glial cell*, which we will discuss later in this lecture.
 1. All neurons go from left to right, at least in diagrams.
 2. On the far left, we have the dendrites, the ears of the neuron, which create chemical excitation in the neuron.
 3. To the right of the dendrite is the cell body, the centerpiece of the cell, where energy is produced.
 - B. A wave of chemical excitation passes from the dendritic end through the cell body down a long cable called the *axon*.
 1. Axons are very long projections of neurons.
 2. The *axon hillock* is the transitional point between the end of the cell body and the start of the axon.
 3. At the end of the axon is the *axon terminal* that connects to the dendrites of the next neuron.
- II. Neuronal communication includes both *resting potentials* and *action potentials*.
 - A. To be prepared to communicate clearly, neurons must concentrate on contrasts during resting potentials. (Figure 2b)
 1. In a state of equilibrium, neurons create chemical contrasts.
 2. Neurons expend a great deal of energy redistributing ions during the resting potentials.
 - B. When new information is transmitted by a single dendritic spine, channels open and ions begin to move, causing a change in the electrical state of the neuron.
 1. No single neuronal input triggers an action potential; there is not enough power for the flow of electrical information to continue.
 2. Integration at the neuronal level occurs because of a process called *summation*.
 - a. *Temporal summation* occurs when the same input is triggered over and over so that it finally moves down the axon.
 - b. *Spatial summation* occurs when enough different dendritic spines are being stimulated at once so that information moves down the axon.
 - c. A neuron cell body is an integrator of the inputs of all the different neurons around it.
 - C. When there is enough of a wave of depolarization to reach the axon hillock, the axon hillock integrates the various inputs and decides whether or not to act.
 1. When the axon hillock is triggered to act, neurons are in action potential.
 2. Action potential does not decrement over space and time; it regenerates and continues passing information through the axon terminals to the next neurons.
 3. The axon hillock is a critical feature of the nervous system.
- III. Glial cells, which were once thought to be unimportant, can wrap around the axon and form a myelin sheath.
 - A. Myelin sheaths create an insulation that increases the speed with which electrical waves move down the axon.
 - B. People are not born with myelin sheaths but develop them after birth. As myelin sheaths form, new skills are possible, including comprehension and production of language and regulation of behavior.

C. Multiple sclerosis is a disease in which the immune system attacks and destroys myelin.

IV. Neurons are a complex, integrated network with interesting implications.

A. The numbers of dendrites, neurons, and connectors vary from individual to individual and can change at different points of the life cycle because of environmental stimulation.

B. Axon hillocks can also change over time and under different circumstances.

C. These neurological differences and changes affect individuality.

Further Reading:

For a good broad introduction to the nervous system:

E. Widmaier, H. Raff, and K. Strang, *Vander, Sherman, and Luciano's Human Physiology*, 9th ed.

For a somewhat more advanced treatment:

J. Nicholls, R. Martin, B. Wallace, and P. Fuchs, *From Neuron to Brain*, 4th ed.

For the best (although more advanced) textbook in the field:

E. Kandel, J. Schwartz, and T. Jessell, *The Foundations of Neural Science*, 4th ed.

Questions to Consider:

1. How have neurons evolved so that they exhibit a huge contrast between being silent and being excited?
2. What are ways in which a typical neuron might differ between two individuals?

Figure 2a

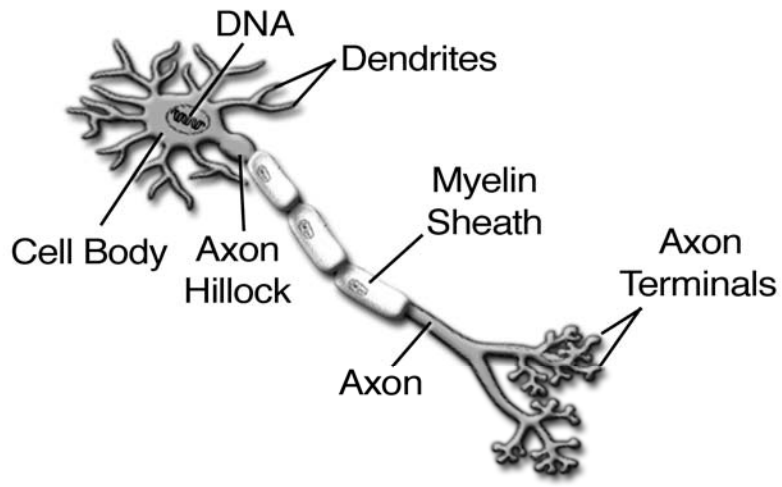
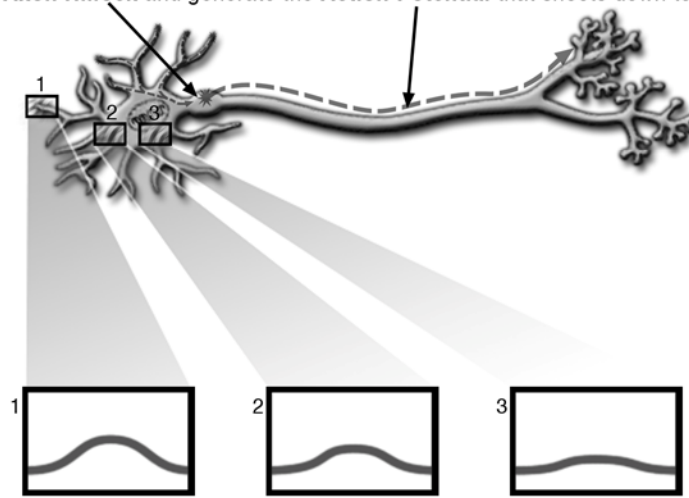

Figure 2b

Adequate inputs are needed to make the wave big enough to suddenly excite the **Axon Hillock** and generate the **Action Potential** that shoots down to the end.



Single wavelets decrement as they move down the cell body. →

Lecture Three

How Two Neurons Communicate

Scope: This lecture moves from how the brain works on the level of a single neuron to how information moves across the synapse from one neuron to the next. Exploring how electrical signals are changed to chemical messages in the brain provides a critical foundation for understanding how the brain works, the effects of certain drugs on the brain, and the neurological origins of individuality.

Outline

- I. In order for information to move from one neuron to the next, information must cross the synapse. (Figure 3a)
 - A. An electrical signal cannot pass through the synapse; thus, a neuron must translate its excitation into a different “language.”
 - B. The release of neurotransmitters translates an electrical signal to a chemical signal.
 1. Neurotransmitters are packaged in vesicles attached to the membrane wall.
 2. During action potential, vesicles release neurotransmitters into the synapse.
 - C. The neurotransmitters bind to their receptors.
 1. The shape of the neurotransmitter and its receptor must be complementary—the classic notion of key and lock.
 2. The binding of the neurotransmitter to its receptor changes the excitability of the next neuron in line.
 3. Multiple receptor types exist for the same neurotransmitter.
 - D. Upon deactivation, neurotransmitters either are recycled back into the next vesicle being formed or they float into the synapse, where they are eventually broken down by enzymes.
 - E. There are multiple types of neurotransmitters and not all are *excitatory*.
 1. How many types of neurotransmitters exist? A limited number, but we have multiple uses of the same messenger.
 2. *Inhibitory* transmitters cause a decrease in excitability of the postsynaptic neuron.
 3. Not all neurotransmitters are equal; there are subtle graduations of the effects among both the excitatory and inhibitory transmitters.
- II. The construction of neurotransmitters is less intimidating than you might think.
 - A. They are constructed from cheap and plentiful precursors—simple amino acids that you get in your diet in huge amounts.
 - B. A small number of biosynthetic steps are required in their construction; thus, they are produced quickly.
 - C. Multiple messengers can be squeezed out of a single synthetic pathway.
 - D. Neurotransmitters are also easily recycled.
- III. What criteria are used to determine what constitutes a neurotransmitter? (Figure 3b)
 - A. It is located in the axon terminal.
 - B. It is released during the action potential.
 - C. It floats across the synapse and binds with receptors on the postsynaptic neuron.
 - D. Any interference with the neurotransmitter will alter the neurochemical events in a predictable manner.
- IV. Now we can better understand how the nervous system changes over time and how individual differences have consequences for behavior.
 - A. Changes in the amount of neurotransmitter released can change the strength of signaling across a synapse.
 - B. Changes in the number and sensitivity of receptors can change the strength of signaling across a synapse.

- V. Neuropharmacology manipulates the neurochemistry of the synapse to better understand the workings of the neurotransmission process.
 - A. Research with drugs that alter brain function is an important tool for studying normal and diseased states.
 - B. Some drugs so closely resemble a naturally occurring neurotransmitter that the receptors are fooled by it.
 - 1. An ingested drug can get into the bloodstream, enter the brain, get into a synapse, and very effectively bind to the receptor because that drug has a chemical structure almost identical to that of an actual neurotransmitter.
 - 2. For example, hallucinogens, such as LSD, mescaline, and psilocybin, are able to artificially stimulate the serotonin receptor.
 - C. Other drugs block the access of a neurotransmitter to its receptor, halting communication across the synapse.
 - 1. Curare can block the acetylcholine receptor in the diaphragm, causing breathing to cease.
 - 2. Antipsychotic drugs can block the dopamine receptor, lessening symptoms of schizophrenia.
 - D. Some drugs cause the inappropriate release of neurotransmitters.
 - 1. Amphetamines and cocaine trigger the premature release of dopamine transmitters.
 - 2. Because the release of dopamine makes a person feel pleasure in at least one part of the brain, artificially releasing more of it makes such drugs as cocaine highly addictive.
 - 3. Drugs that release dopamine can trigger schizophrenic behavior, while drugs that block dopamine are used to halt schizophrenic behavior.
 - E. Some drugs alter the breakdown and recycling of neurotransmitters or can be used to destroy particular neurotransmitters completely.
 - 1. The neurotransmitter norepinephrine can be destroyed to lower blood pressure.
 - 2. Antidepressants, including Prozac, cause amplification in the neurotransmitter's signal by blocking its degradation.
 - F. Another manipulation is to increase the amount of precursors for certain neurotransmitters, for example, increasing the L-DOPA level for patients with Parkinson's disease.
 - G. Manipulation of chemicals always has the risk of side effects, primarily because each neurotransmitter has multiple jobs in different parts of the brain.
- VI. An example of how neurochemistry influences individuality can be seen in the neurotransmitter endogenous benzodiazepine, which is a compound similar to the drugs Valium and Librium.
 - A. Endogenous benzodiazepine receptors influence anxiety levels.
 - B. How much benzodiazepine an individual makes, releases, and breaks down will determine his or her anxiety level.
 - C. Tranquilizers, such as Valium and Librium, are used to decrease a person's anxiety level.

Further Reading:

For the best introductory book specifically about neurotransmission:

J. Cooper, F. Bloom, and R. Roth, *The Biochemical Basis of Neuropharmacology*, 8th ed.

For a more difficult text:

G. Siegel and B. Agranoff, *Basic Neurochemistry: Molecular, Cellular, and Medical Aspects*, 6th ed.

For a particularly good overview of what neurotransmitters have to do with mental illness:

S. Barondes, *Molecules and Mental Illness*, 2nd ed.

Questions to Consider:

1. What is the chemical nature of neurotransmitters, and how can drugs alter their function?
2. What are the ways in which the neurochemistry of two individual brains might differ?

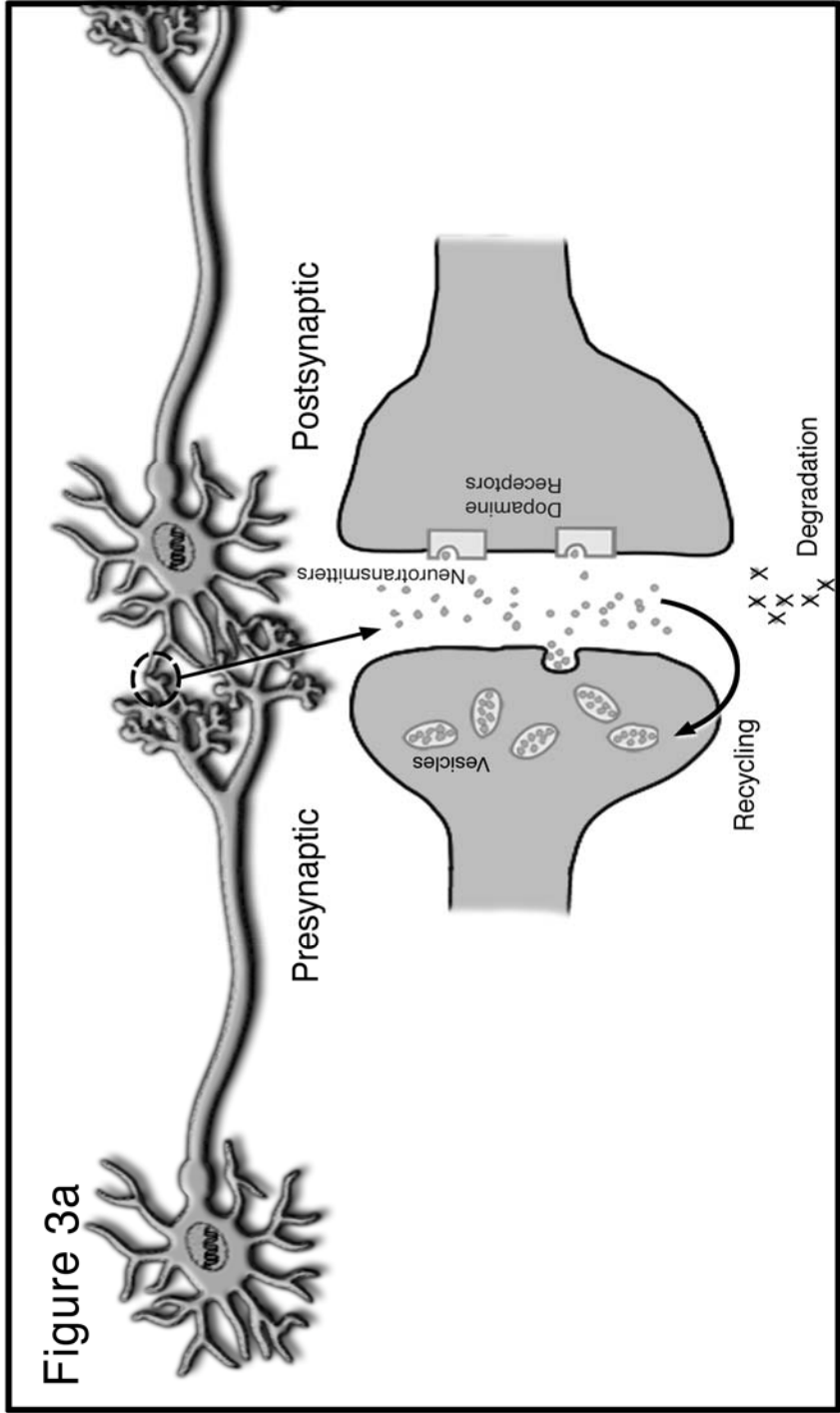
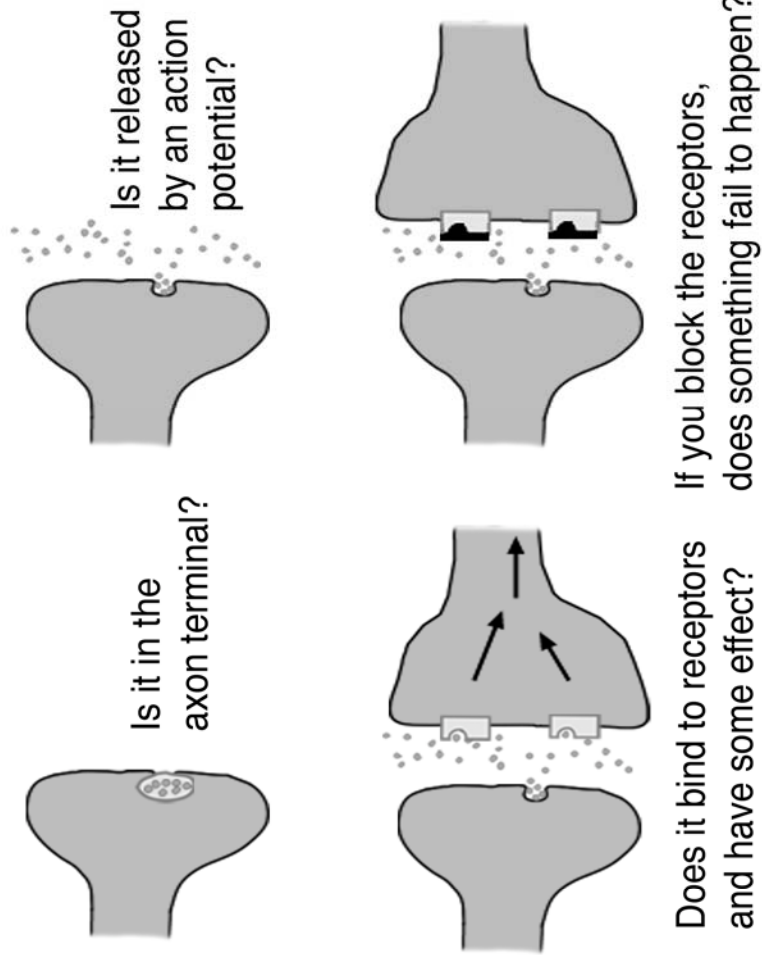

Figure 3a

Figure 3b



Criteria for
Neurotransmitter

Lecture Four

Learning and Synaptic Plasticity

Scope: This lecture examines how communication within and between neurons changes as a result of experience. Particular emphasis is placed on *long-term potentiation* (LTP), including an explanation of how the process occurs in two different parts of the brain: first, in the hippocampus, with implications for learning and memory, and second, in the amygdala, with implications for fear and anxiety. Ways that the LTP process is enhanced and disrupted, both naturally and artificially, are also investigated.

Outline

- I. Changing the strength of synaptic communication is the basis for learning.
 - A. The dominant paradigm is that learning is the process of making certain pathways work more readily than they did before.
 - B. In earlier times, it was believed that whenever something new was learned, a new neuron or a new synapse was formed; this may actually be true.
 - C. The cortex and hippocampus are the main regions of the brain responsible for learning and memory.
 1. Problems in the hippocampus may result in such diseases as Alzheimer's disease.
 2. The famous case of H.M., who had his hippocampus removed, shows the importance of the hippocampus to memory.
- II. *Long-term potentiation* (LTP), a synaptic model for learning, is the process of stimulating a dendritic spine in a dense cluster of rapid action potentials, resulting in that synapse becoming hyperresponsive or *potentiated*. (Figure 4a)
 - A. After potentiation has occurred, the pathway is stronger.
 - B. Potentiation increases the likelihood that a single neuron can cause an action potential.
 - C. These changes are long lasting.
- III. How does the initial phase of LTP work?
 - A. LTP is the result of glutamate being released into synapses throughout the hippocampus.
 1. Glutamate is a simple neurotransmitter made from an amino acid.
 2. Glutamate is the most excitatory neuron with two receptor systems, each of which is differentially excitable.
 - B. The workings of the two receptors explain the "Ah ha!" of learning. With repeated stimulation, enough glutamate is dumped into the synapses to open the second receptor, which allows a wave of excitatory calcium to pour in, causing great potentiation.
- IV. How does LTP become long term? (Figure 4b)
 - A. As LTP occurs, calcium enters the neuron.
 1. Calcium triggers an increase in the number of glutamate receptors in the relevant dendritic spine.
 2. Calcium causes the receptors to stay open and activated longer once they are excited.
 3. Calcium changes how readily the electrical wave spreads once there is some excitation.
 - B. Once calcium rushes in, it causes the synthesis of a neurotransmitter that floats back to the presynaptic neuron.
 1. These retrograde neurotransmitters increase the amount of glutamate being synthesized by the presynaptic neuron.
 2. Some of these new transmitters are made from gases and, therefore, do not need vesicles.

- V. The vulnerability of *glutamatergic* pathways to neurological insults is relevant to a number of neurological diseases and disorders.
- A. If glutamate levels get too high (a condition called *excitotoxicity*), the postsynaptic neuron can be excited to death. This condition can occur in stroke, seizure, and cardiac arrest.
 - B. Monosodium glutamate (MSG) and other dietary constituents that resemble glutamate may be worth worrying about.
- VI. How do you forget anything?
- A. This is an important topic in the field of neurobiology, and it is still under study.
 - B. In some manner, however, forgetting is thought to be a reversal of all the steps that we have just covered regarding LTP.
- VII. Several factors influence how readily LTP occurs.
- A. Some factors are known to enhance LTP.
 1. Abundant energy—lots of glucose in your blood that translates into neurons with more energy—facilitates LTP.
 2. Short-term stress (stimulation) causes stress hormones to be released on a short-term basis, and these hormones enhance memory.
 - B. Some factors are known to disrupt LTP.
 1. Energy depletion makes LTP less likely to occur. When you run out of energy, the whole transport of neurotransmitters is disrupted.
 2. Chronic stress, unlike short-term stress, disturbs many types of memory consolidation and memory retrieval.
 3. Alcohol in sufficient amounts dramatically disrupts LTP.
- VIII. Individual differences in the area of LTP can manifest themselves in a number of ways.
- A. The amount and functions of neurotransmitters, receptors, and so on can vary greatly from person to person.
 - B. An experiment at Princeton provides an interesting view on this subject.
 1. Scientists at Princeton developed Doogie mice, genetically engineered rodents that had better than average LTP and demonstrated better than average learning.
 2. Then, the scientists developed their less heralded cousins, mice with an impaired capacity for LTP and learning.
 3. They then raised the impaired mice in an extremely stimulating environment, which overcame their deficit.
 4. This experiment shows that even something as seemingly deterministic as a major genetic defect can still be subject to important environmental modulation.

Further Reading:

For a good, although by now somewhat dated, introduction to the neurobiology of learning and memory, including LTP:

L. Squire, *Memory and Brain*.

For an excellent neuroscience textbook that covers LTP in some detail:

L. Squire, *Fundamental Neuroscience*, 2nd ed.

Questions to Consider:

1. What are the ways in which synaptic function can change in response to experience?
2. How might neurons differ in the ease with which those changes occur?

Figure 4a

What Happens During LTP

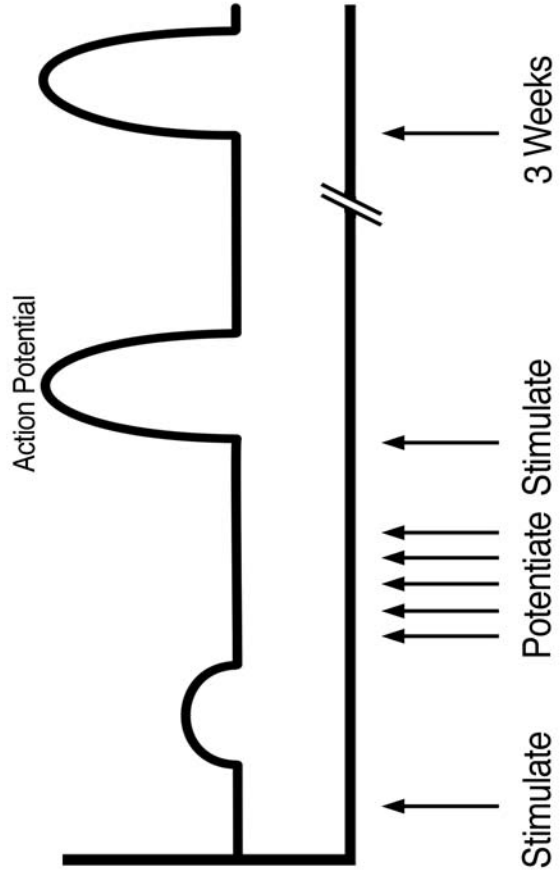
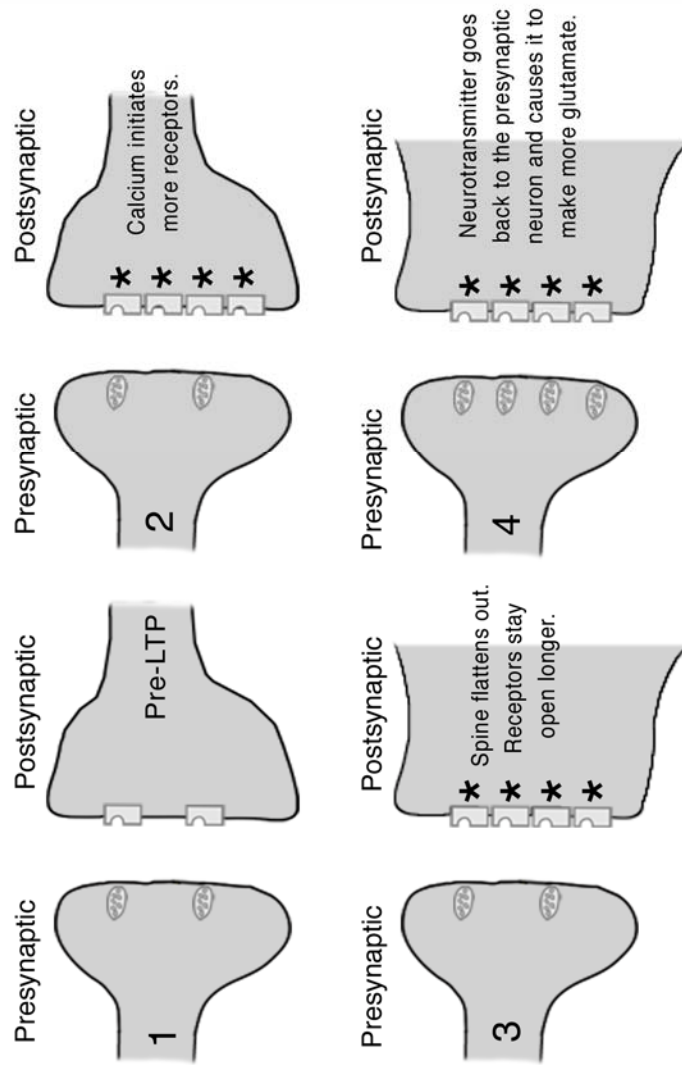

Figure 4b

Mechanisms of LTP



Module II

The Neurobiology of Behavior at the Systems Level

Module Scope:

This portion of the course expands the scale beyond that of cellular neurobiology to look at the functioning of networks of neurons. Lecture Five is an introduction to the computational potential of neuronal networks. Lecture Six is an examination of how millions of neurons—entire subregions of the brain—function. That lecture will specifically focus on the part of the brain called the *limbic system*, which is vitally concerned with emotion. Finally, Lecture Seven examines how the limbic system regulates the function of the body by way of the autonomic nervous system.

Lecture Five

The Dynamics of Interacting Neurons

Scope: The next integrative level of neuron function examines how networks of neurons carry out complex processes. We will study how neurons sharpen detection signals through inhibition and how layers of neurons that overlap and form networks directly impact individual memory, pain, and creativity.

Outline

- I. The brain consists of networks of neurons.
 - A. The brain has far more than patterns of single neurons in line.
 - B. Instead, neurons send axons to many other neurons, sending branches off, even back to themselves, forming networks.
- II. Neurons sharpen the detection of signals by inhibiting themselves and other neurons.
 - A. Neurons communicate with themselves. (Figure 5a)
 1. The ability of neurons to have projections coming off the axon and sending projections back onto themselves (called *recurrent collateral projections*) allows them to inhibit themselves and sharpen their signals over time.
 2. This communication creates individual action potentials, followed by resting potentials.
 3. Recurrent collateral projections are seen in many neurons.
 - B. Through lateral inhibition, neurons sharpen their signals over space. (Figure 5b)
 1. The excitation of one neuron leads to the delayed inhibition of other neurons.
 2. This lateral inhibition helps to enhance the precise localization of information.
- III. The work of Hubel and Wiesel helped to explain the wiring of neural networks. (Figures 5c, 5d, and 5e)
 - A. By studying how each section of the cortex processed visual information, they were able to show that each layer of the cortex became increasingly sophisticated.
 1. Point-for-point mapping at the first layer indicated that these neurons “know” about dots of light.
 2. The neurons in the second layer of the cortex “know” about straight lines of light.
 3. The neurons in the third layer of the cortex “know” about moving lines, while the neurons in the fourth layer “know” about angles.
 - B. Following this logic, it was believed that one could continue through the layers and find even more super-specialized neurons that recognize more specific information (for example, “the grandmother neuron” that could recognize a grandmother’s face).
 1. This finding was not possible because there could not possibly be enough neurons for each to contain a single piece of information.
 2. It is not single neurons that contain information but patterns of neuronal excitation.
 - C. A neural network is a series of neurons that interact among themselves and with neurons from other networks.
 1. Neurons from different networks can overlap and be used in different settings.
 2. Memory retrieval is the result of tapping into many networks and integrating all those inputs.
 3. Mild neuron loss, including that associated with early-stage dementia and Alzheimer’s disease, does not destroy memories as much as it makes it harder to retrieve memory.
- IV. Neural networks also influence how the human body feels and responds to pain. (Figure 5f)
 - A. In instances of sharp pain, the neurons directly affected “turn on” pain, and through inhibition, the pain is “turned off.”

- B. In instances of dull pain, those neurons directly affected “turn on” pain; however, the lack of self-inhibition causes the throbbing to continue.
 - C. The loss of the more “expensive” pain pathways helps explain chronic pain in diabetes.
 - D. Stimulating adjacent pathways shuts down the pain (for example, back rubs and scratching around a maddeningly itchy mosquito bite).
- V. It is the individual differences that exist in the overlapping projections of networks that cause people to know different information and to make different connections with that information. That is what creativity is about. On a simplistic level, creative people have broader networks than most other people, resulting in their ability to make unique associations.

Further Reading:

All of the following neuroscience textbooks have good sections on this subject:

E. Kandel, J. Schwartz, and T. Jessell, *The Foundations of Neural Science*, 4th ed.

J. Nicholls, R. Martin, B. Wallace, and P. Fuchs, *From Neuron to Brain*, 4th ed.

L. Squire, *Fundamental Neuroscience*, 2nd ed.

L. Squire, *Memory and Brain*.

Questions to Consider:

1. How might the “wiring” of networks differ between individuals and, thus, explain differences in their functioning?
2. How might wiring networks develop in the fetal brain?

Figure 5a

Recurrent Collateral

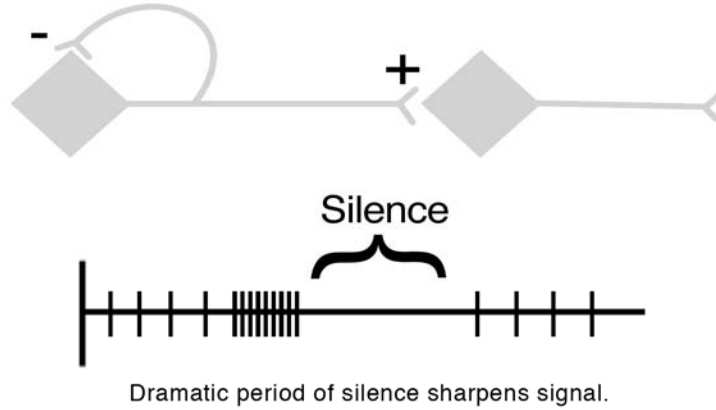
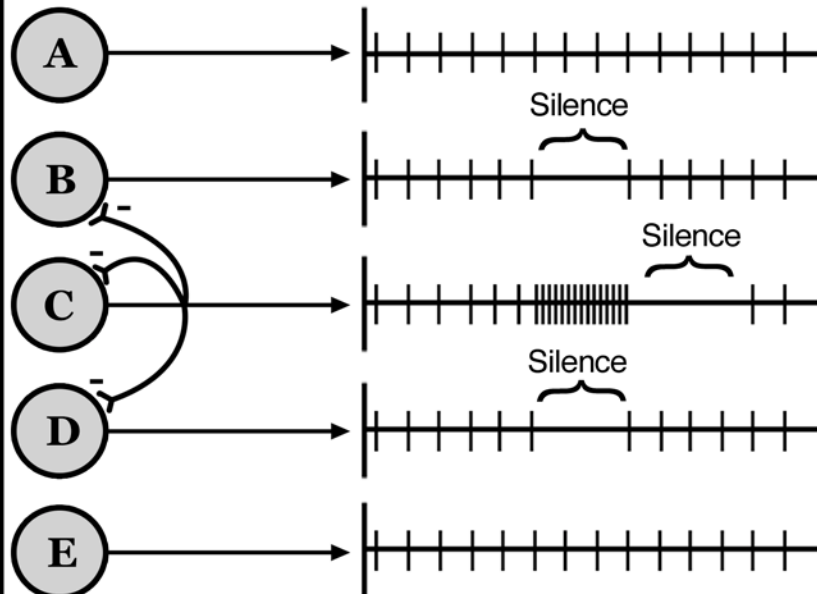

Figure 5b

Lateral Inhibition



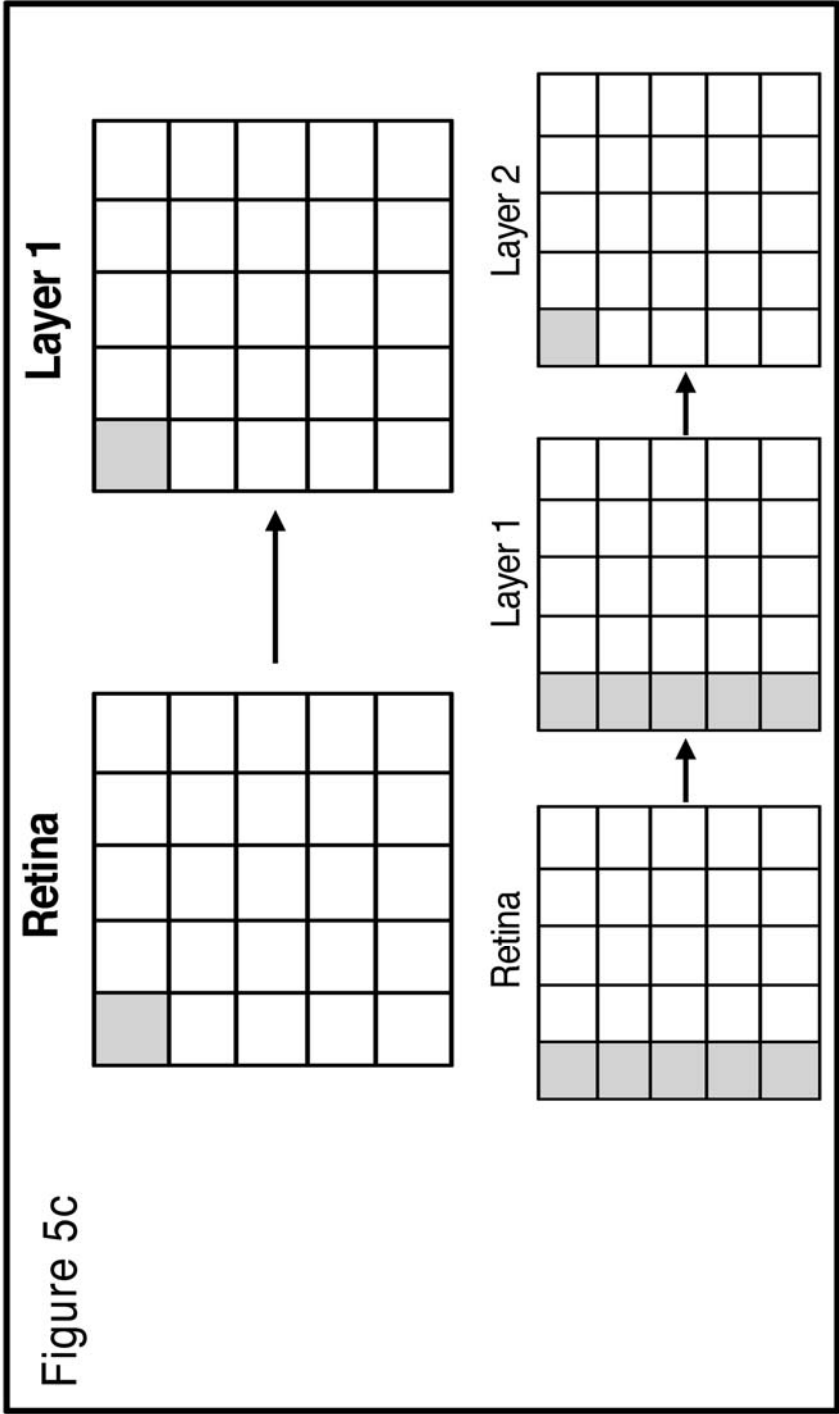

Figure 5d

Neural Network Example 1

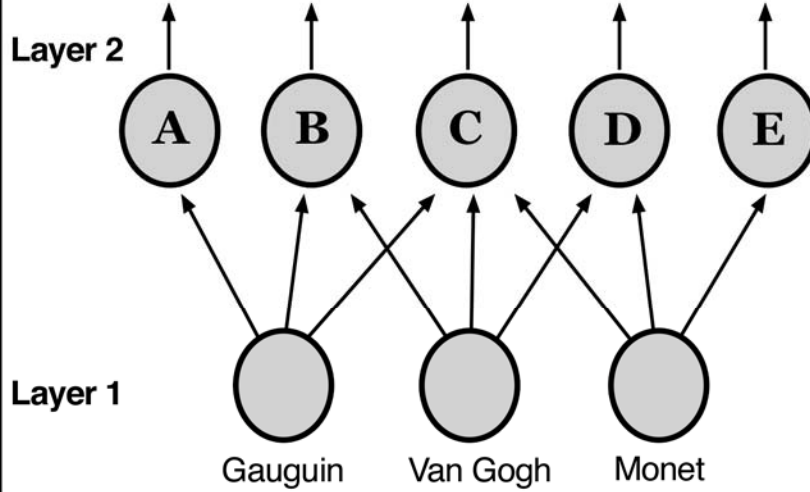
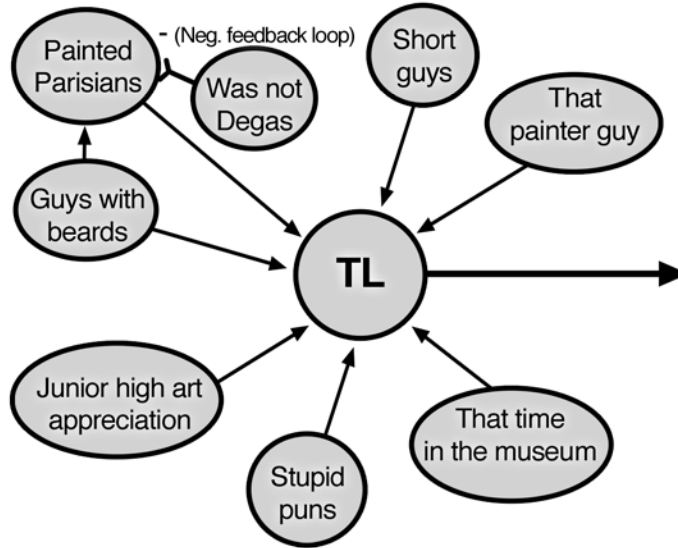
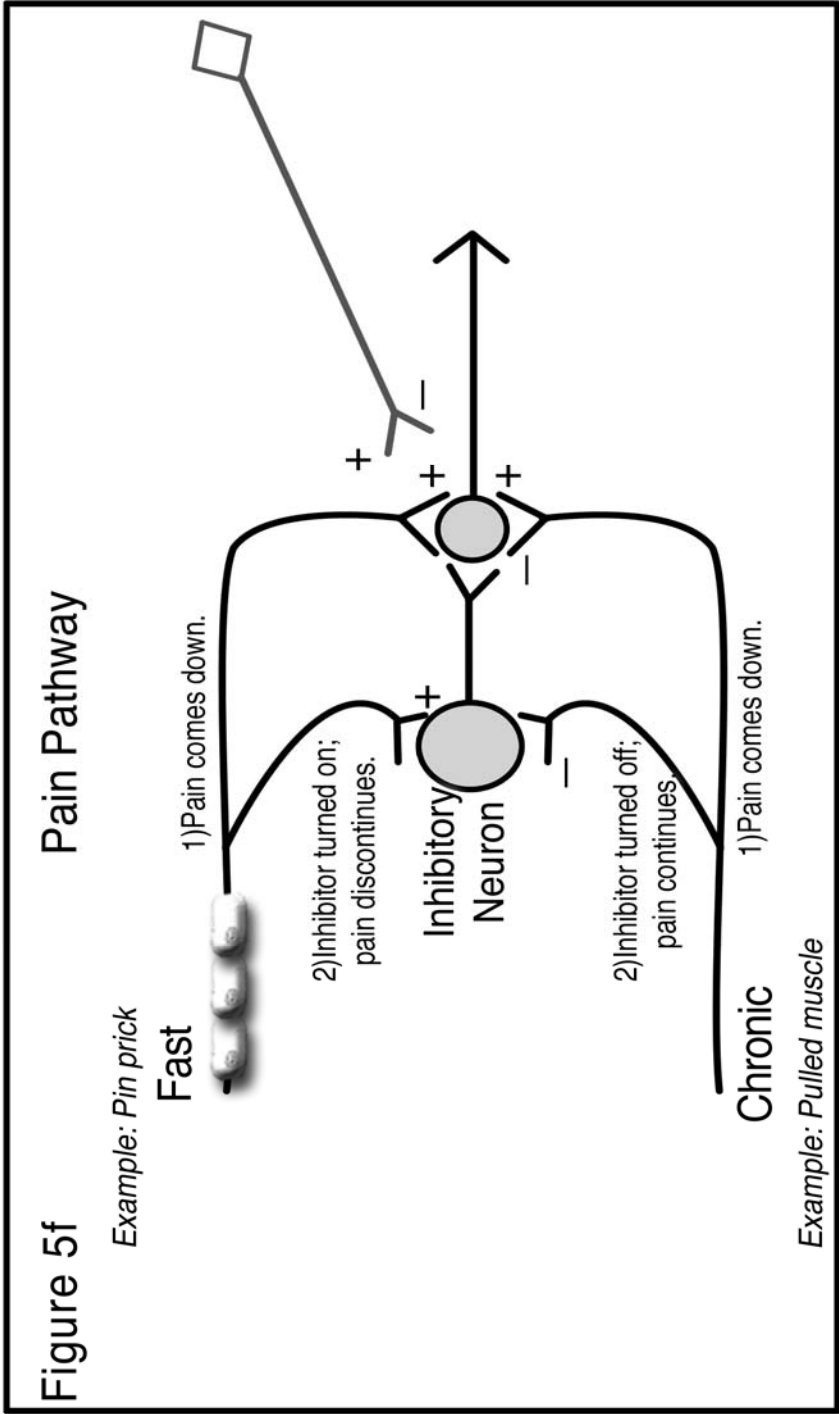

Figure 5e

Neural Network Example 2





Lecture Six

The Limbic System

Scope: Increasing the scale beyond that of single neural networks, this lecture examines the *limbic system*—the part of the brain most centrally involved in emotion and in generation of emotionally related behavior. We will begin with a brief overview of how the limbic system is organized anatomically, followed by an introduction to its roles in aggression, fear, anxiety, sexual behavior, and depression.

Outline

- I. The brain is not one homogenous mass of undifferentiated neurons. Instead, there is structure and organization to it.
 - A. Clusters of neuronal cell bodies, called *gray matter*, are the nuclei of cell bodies.
 - B. Cables of axons are projections from those cell bodies. They are called *white matter* because they are wrapped in white myelin sheaths.
- II. Now, we expand one step further to the neuroanatomy of the brain.
 - A. First, we see the broad features of the mammalian brain. (Figure 6a)
 1. Heading down from the brain are the spinal cord, sensory afferents, and motor efferents, all of which carry sensory information and messages to all parts of the body.
 2. At the back of the brain are the hindbrain and brainstem, which control such activities as breathing and the beating of the heart.
 3. Sitting on top of the hindbrain and brainstem is the limbic system, which deals with regulation of emotions.
 4. Higher up is the cortex, involved in memory, learning, judgment, decision making, conscious commands to muscles, and complex processing of sensory information.
 - B. Species differences in neuroanatomical organization must be noted.
 1. The limbic system is a mammalian specialty; only mammals have complex emotions.
 2. The cortex, which is involved in social intelligence, is a primate specialty.
- III. What is the limbic system? (Figure 6b)
 - A. Historically, people used to think that the limbic system was the *rhinencephalon*, or “nose-brain,” because it was studied first in laboratory rats, for which olfaction and emotion are utterly intertwined.
 - B. The limbic system comprises many different subareas.
 1. These subareas send projections to one another and to other parts of the brain, particularly to the hypothalamus.
 2. All of the brain nuclei in the limbic system want to influence the hypothalamus.
 3. Conversely, these nuclei want to inhibit other limbic sites from influencing the hypothalamus.
 4. The hypothalamus controls all manner of autonomic (automatic) functions in your body. Future lectures will address the hypothalamus in more detail.
 - C. The best way to determine which limbic structure influences the hypothalamus most readily is to count synapse numbers. The fewer synapses it takes to get from one limbic structure to the hypothalamus, the more influential that structure is over the hypothalamus.
- IV. Components of the limbic system include major structures, as well as major connections within the system. (Figures 6c and 6d)
 - A. Major structures within the limbic system include the amygdala, the hippocampus, the septum, the cingulate cortex and gyrus, the hypothalamus, the mammillary bodies, the thalamic nuclei, and the frontal cortex.

- B. Major connections within the limbic system include the amygdalofugal pathway (amygdala to hippocampus); the fimbria/fornix (hippocampus to septum); the striae terminalis (amygdala to hypothalamus); the medial forebrain bundle (the highway between the mammillary bodies and the septum, passing through the hypothalamus); and the mammillothalamic tract (mammillaries to thalamus).
- V. How do we know what the limbic system does?
- A. Scientists come to understand what the limbic system does in the same ways that they discover how any brain region works.
 1. One way is to experimentally damage the part of the brain to be studied in research animals. Accidental wounds to the human brain can provide similar information.
 2. Other strategies are to stimulate certain parts of the brain or to record the electrical activity of certain clusters of neurons.
 3. A relatively new method is brain imaging.
 4. A more classical approach is neuroanatomy: determining which region talks to which.
 5. Some pitfalls of these approaches include redundancy, compensation, and mistaking the function of a nucleus for the function of the fibers passing through it.
 - B. Studying limbic function poses special challenges because this area of the brain deals with complex, subtle, interactive emotions; therefore, many factors must be kept in mind.
 1. What sort of sensory information is relevant in a particular species? For example, sexual arousal in one species can be about smell and in another, about sight.
 2. What does a behavior look like in a particular species? For example, maternal behavior in a rat is very different from that in a monkey.
 3. Who is the individual under study? Do dominant and subordinate animals express emotions in the same way?
- VI. Simplified explanations of some functions for limbic structures are helpful to further understand the brain and behavior.
- A. The amygdala and septum have roles in aggression.
 - B. The hippocampus is important in certain types of learning, memory, and stress-responsiveness.
 - C. Mammillary bodies are associated with maternal behavior.
 - D. The frontal cortex controls inhibition of socially inappropriate behaviors and inhibition of perseverative cognitions.
 - E. The medial preoptic region of the hypothalamus is associated with sexual behavior.
 - F. The lateral and ventromedial hypothalamus affect hunger and satiation.
 - G. The suprachiasmatic nucleus of the hypothalamus is involved in circadian rhythmicity.

Further Reading:

For a particularly strong book on this topic:

M. Konner, *The Tangled Wing: Biological Constraints on the Human Spirit*.

For additional information on this subject:

J. LeDoux, *The Emotional Brain: The Mysterious Underpinnings of Emotional Life*.

J. LeDoux, *Synaptic Self: How Our Brains Become Who We Are*.

For a classic on the subject by one of the key people in the field:

P. MacLean, *The Triune Brain in Evolution: Role in Paleocerebral Functions*.

Questions to Consider:

1. What will the structure and function of the limbic system in a particular species tell you about the social behavior of that species?

2. How are interactions between the limbic system and the cortex particularly interesting in humans?

Figure 6a

Basic Mammalian Structures

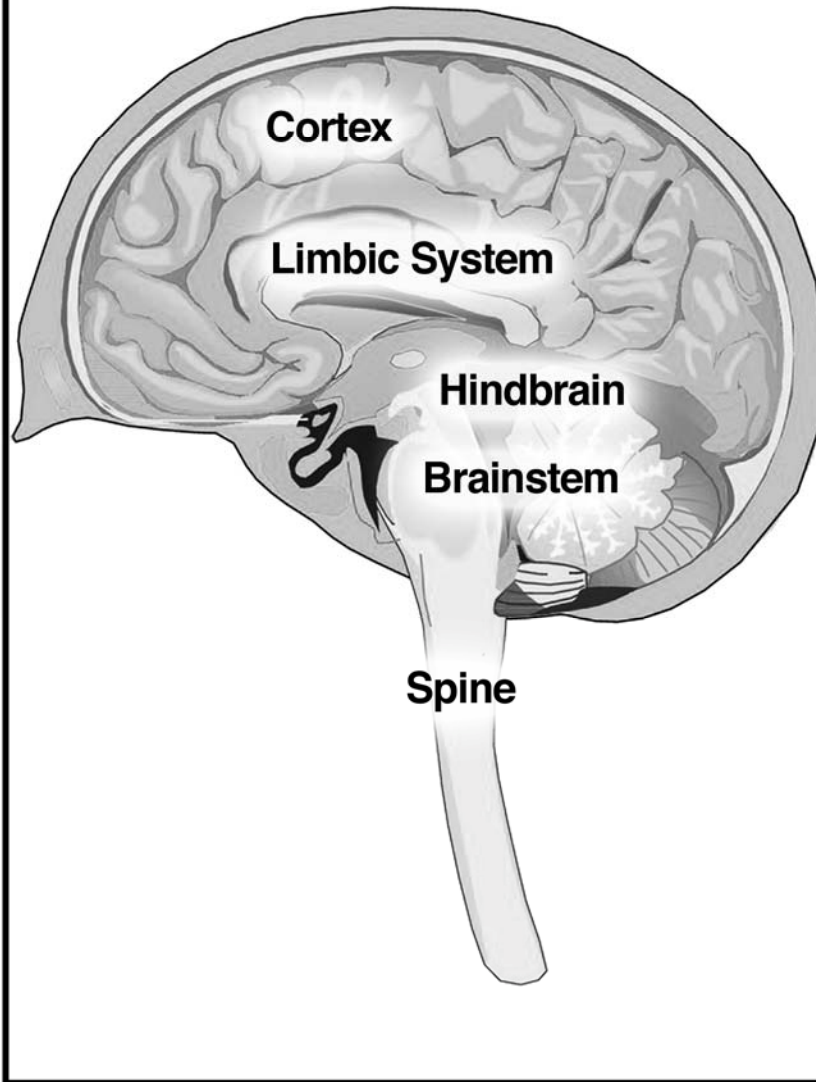

Figure 6b

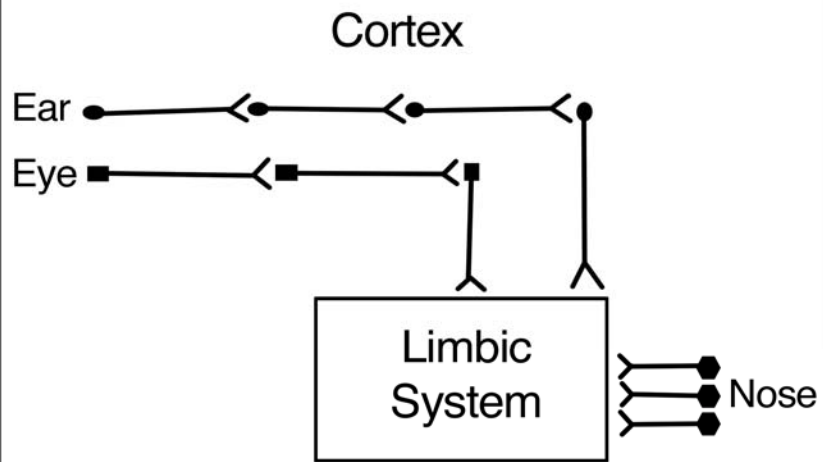
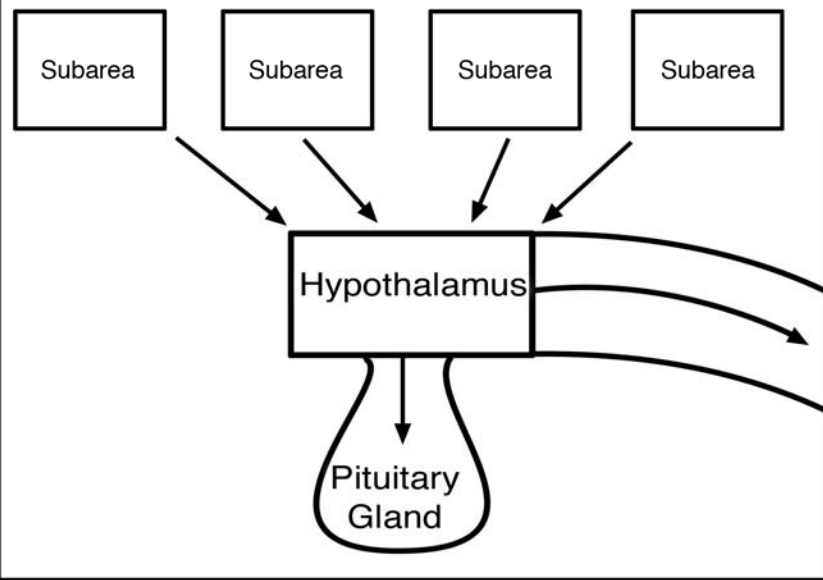
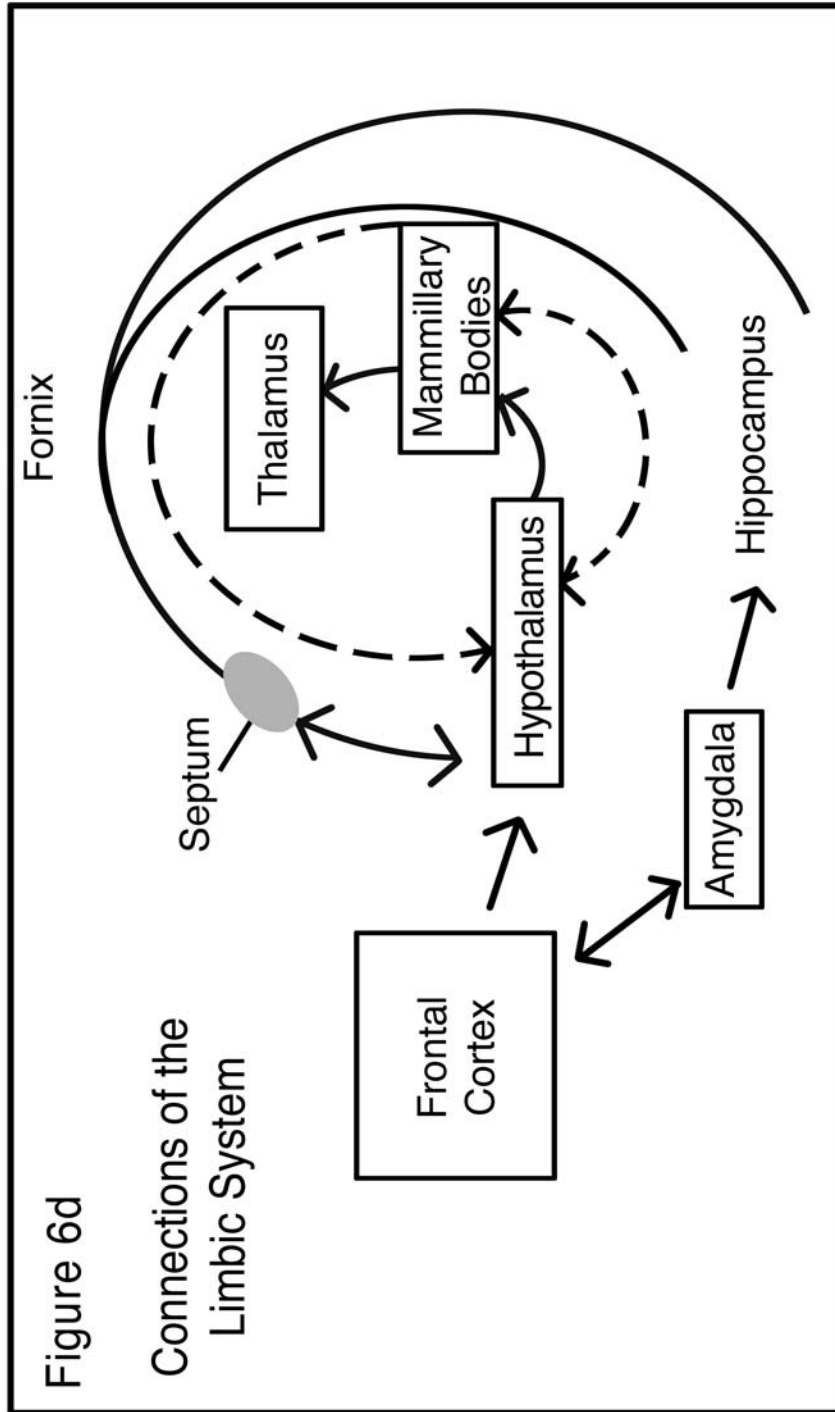

Figure 6c

Components of the Limbic System





Lecture Seven

The Autonomic Nervous System (ANS)

Scope: This lecture examines the workings of the *autonomic nervous system* and its subparts, the *sympathetic nervous system* and the *parasympathetic nervous system*. The lecture also investigates how the autonomic nervous system regulates the organs of the body, how different levels of the brain activate the system, and how the system is strengthened. The lecture ends with a glimpse into ways that the autonomic nervous system influences individual differences.

Outline

- I. We start with the basics of the ANS.
 - A. The voluntary nervous system controls the rapid regulation of skeletal muscles.
 - B. In contrast, the ANS regulates involuntary function throughout the body.
 - C. The ANS has two components.
 1. The *sympathetic nervous system* (SNS), which releases epinephrine and norepinephrine (adrenalin and noradrenalin), is used for emergencies.
 2. The *parasympathetic nervous system* (PNS) releases acetylcholine, which triggers a calm, vegetative state.
- II. The SNS and PNS work in choreographed opposition in all parts of the body. (Figure 7a)
 - A. Although the heart is able to beat on its own, the brain tells it whether to speed up or slow down.
 1. The SNS causes the heart to beat faster and blood pressure to increase, all as a strategy to deliver energy to exercising muscle.
 2. The PNS does the opposite, slowing down the heart.
 - B. SNS and PNS also interact during digestion.
 1. Under normal circumstances, the PNS stimulates the digestive tract.
 2. During an emergency, the SNS has the opposite effects. It shuts down digestion and blood flow to the gastrointestinal tract to ensure that energy is not wasted there.
 - C. The SNS and PNS work in a more coordinated fashion when a male becomes aroused.
 1. In order for the penis of a male to become erect, the PNS must be activated and, thus, requires that he be in a calm state.
 2. The SNS, however, slowly takes over, and when the PNS is turned off, ejaculation occurs.
 3. Syndromes of erectile dysfunction include stress-induced erectile dysfunction, during which stress prevents a man from attaining a state of calm and, thus, an erection, and premature ejaculation, during which the transition from PNS to SNS occurs more quickly than desired. Both are disorders of the choreography between the PNS and SNS.
- III. The ANS is activated and regulated differently in three layers of the brain. (Figure 7b)
 - A. The first regulation of the ANS is directly influenced by the hypothalamus. For example, if a person is injured and his or her blood pressure is dropping, a blood pressure sensor sends a message up the spinal cord to the hypothalamus, which stimulates the SNS, increasing blood pressure and heart rate.
 - B. In the second layer, the ANS is regulated by the limbic system. For example, the scent or the sight of a threatening rival is detected, causing an emotional response and sending a message to the hypothalamus, which in turn, activates the ANS.
 - C. In the third layer, we have cortical regulation of the ANS in a way that is fairly unique to primates.
 1. Cortical projections are sent to the limbic system, including the hypothalamus, to activate the ANS.
 2. Thought and memory serve as stimulants of the ANS.
 3. This method of activation gives us insight into the cause of clinical depression.

- a. On a certain level, depression can be thought of as the cortex sending abstractly depressive thoughts into limbic and hypothalamic regions, resulting in the affect of depression (as well as overactivity of the stress response).
- b. A clinically depressed person feels grief, exhaustion, and an absence of pleasure, called *anhedonia*.

IV. Plasticity in ANS function over time manifests itself in three ways.

- A. *Habituation* is the process whereby the same stimulus will not have the same effect on the ANS.
- B. *Sensitization* is the process whereby a stimulus that once did not have an effect on the ANS now does.
- C. *Biofeedback* is a conscious tool for controlling the unconscious workings of the ANS; for example, thinking relaxing thoughts can reduce the SNS response.

V. Individual differences in ANS function explain why some of us are more vulnerable to depression or anxiety disorders than others.

Further Reading:

For a particularly nice, accessible treatment of the subject:

J. Kalat, *Biological Psychology*, 8th ed.

Questions to Consider:

1. How does the autonomic nervous system translate events in the mind into changes in the body?
2. What are the distinctive features of autonomic function in humans?

Figure 7a

Autonomic Nervous System

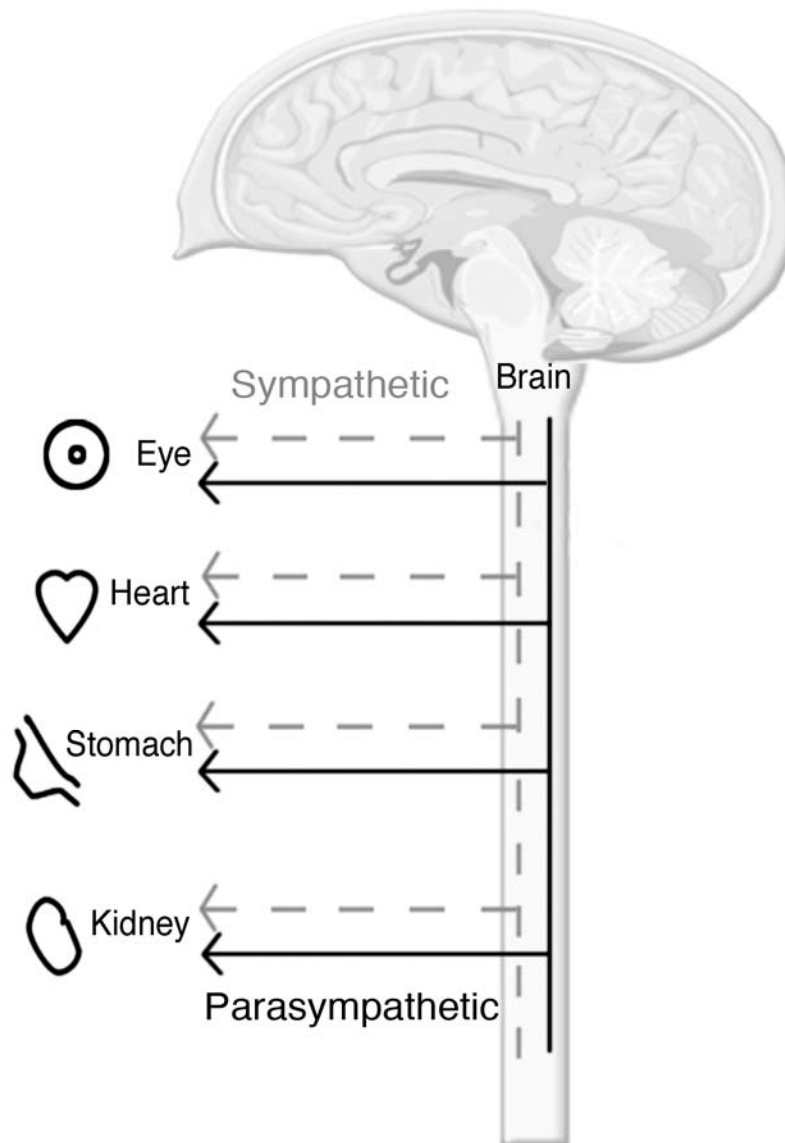

Schematic Outline of the Brain

Axonal projections into key brainstem structures

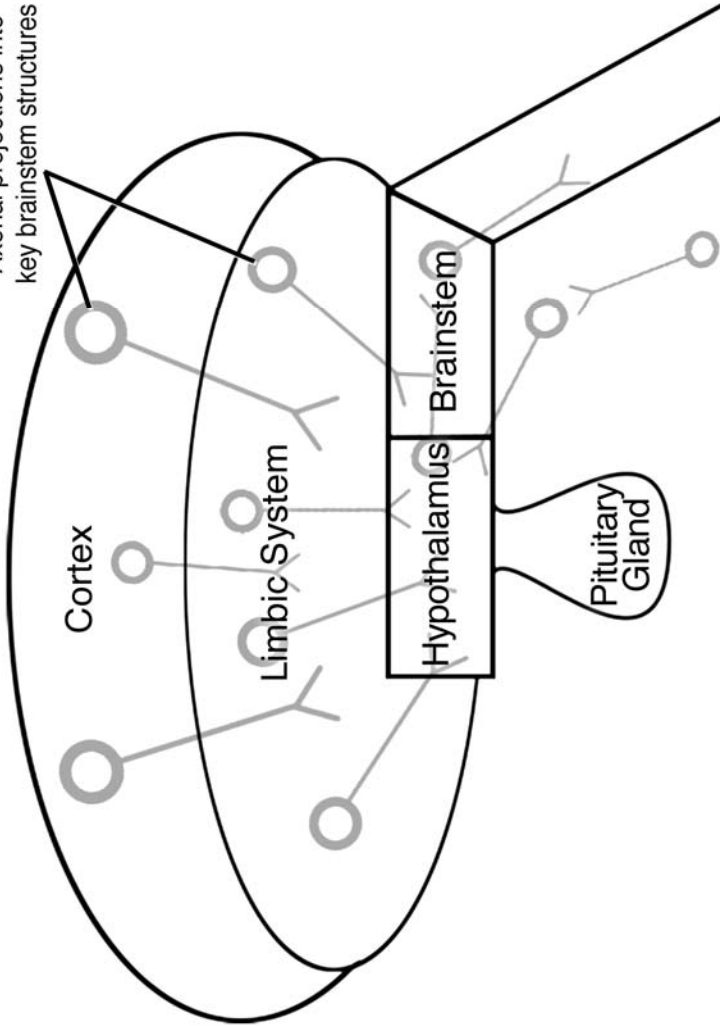

Figure 7b

Module III

The Neuroendocrinology of Behavior

Module Scope:

The lectures on the brain ended with an overview of how the brain (via the limbic system) regulates the body by way of the ANS. Starting with Lecture Eight, this module first examines how the limbic system also regulates the body through the release of hormones. Following that is a review of the different types of hormones and what sort of effects they have. Lecture Nine considers the converse of the brain's regulation of hormones, namely, the hormones' regulation of the brain. How can hormones change the function and even the very structure of the brain? The main point of these lectures is to refute the notion that hormones "cause" behaviors to occur (for example, the notion that testosterone "causes" aggression) and, instead, to explain how hormones interact with the nervous system to change the likelihood of behaviors occurring in certain environments.

Lecture Eight

The Regulation of Hormones by the Brain

Scope: Lecture Seven introduced the ANS, a means by which the brain can regulate the function of organs throughout the body. This lecture introduces the other route by which the brain can accomplish this regulation, namely, by regulating the release of numerous types of hormones. The nature of this regulation is reviewed, as are the basic ways in which hormones work.

Outline

- I. What is the difference between a neurotransmitter and a hormone?
 - A. Neurotransmitters travel across synapses and influence the next neuron in line, while hormones travel in the bloodstream.
 - B. There are three other major differences between neurons and hormones.
 1. Hormones work more slowly than neurotransmitters.
 2. Neurons communicate only with neurons; hormones influence every cell in the body and can be secreted from various parts of the body.
 3. Hormones have a broader effect on cells.
 - C. The brain plays a critical role in regulating the endocrine systems.
- II. The hypothalamus is the center of the endocrine world, and the limbic system tries to tell the hypothalamus what to do. (Figure 8a)
 - A. The earlier view was that peripheral glands were autonomous and self-regulating.
 - B. This notion then gave way to the equally incorrect idea that the pituitary was the “master gland.”
 - C. It is understood now that the brain is an endocrine gland and that the hypothalamus secretes an array of hormones, which in turn, regulate the pituitary gland.
- III. The anterior pituitary is a hormonal system that is entirely under the control of the brain.
 - A. The hypothalamus releases hormones to stimulate or inhibit the pituitary gland cells.
 - B. The anterior pituitary, in turn, regulates hormonal release from peripheral glands.
- IV. The posterior pituitary is another hormonal system that is entirely under the control of the brain.
 - A. The posterior pituitary can be considered an outpost of the brain.
 - B. The posterior pituitary releases oxytocin and vasopressin, hormones that play roles in birth and lactation.
- V. The body also has hormonal systems that are under partial control by the brain.
 - A. One example is the pancreas, which produces a number of hormones, the most recognized of which is insulin.
 - B. Insulin secretion is triggered by blood glucose, and it is also triggered through the PNS by the expectation of food.
- VI. The body also has hormonal systems that are independent of the brain. In such cases, hormones are derived from all sorts of unlikely sources, such as the heart and the immune system. (Figure 8b)
 - A. When the heart senses high blood pressure, it releases a hormone, ANF, to the kidneys to tell them to make more urine, thereby reducing the amount of fluid in circulation; as a result, blood volume is reduced and blood pressure is lowered.

- B. The immune system also has messengers that act as hormones. One of them, Interleukin 1, triggers white blood cells to proliferate and mount an immune defense against a pathogen that the system has detected. Interleukin 1 can also affect brain function, bringing about fatigue or fever and making one's body ache by sensitizing pain pathways, and it can trigger a stress response. All these events are ways to make a person decrease activity during illness.

VII. There are two broad classes of hormones.

- A. Steroid hormones include estrogens, androgens, progestins, glucocorticoids, and mineralocorticoids.
- B. The other class of hormones is made from amino acids; that is, they are protein based. They include insulin, follicle-stimulating hormone (FSH), and growth hormone.
- C. For both classes, we see the themes of cheap and plentiful starting material, short synthetic pathways, and multiple messengers derived from the same precursors. But cheap messengers require very fancy and expensive receptors to tell apart these structurally similar hormones.

VIII. Hormone receptors are as critical to the endocrine system as the hormones they receive.

- A. Hormones bind to receptors and, thereby, activate events in cells.
- B. Amino acid-derived hormones tend to influence the activity of proteins that already exist in the cell (for example, epinephrine mobilizing energy from storage sites during an emergency).
- C. Steroid hormones tend to alter the synthesis of new proteins.
- D. The amount of a hormone in the bloodstream is important, but so are the amount and function and possible mutation of hormone receptors.

IX. A great deal of crosstalk exists between different endocrine systems. An example of such crosstalk is seen in the effects of stress on female reproduction. (Figure 8c)

- A. The ovarian axis illustrates the pathway.
 - 1. The hypothalamus releases the luteinizing hormone releasing hormone (LHRH).
 - 2. The LHRH causes the anterior pituitary to release the luteinizing hormone.
 - 3. The ovaries are then triggered to release estrogen, causing the uterine wall to mature.
- B. If you add any major form of stress, such as starvation or psychological trauma, stress hormones will influence every step in that pathway.
 - 1. Stress and its effects on hormone release from fat cells show that starvation is an antireproductive form of stress. Likewise, excessive amounts of exercise can cause the release of beta-endorphins, which, along with other stress hormones, can also have antireproductive effects.
 - 2. Stress-induced release of prolactin disrupts uterine maturation.

Further Reading:

For two excellent texts:

J. Becker, M. Breedlove, D. Crews, and M. McCarthy, *Behavioral Endocrinology*, 2nd ed.

R. Nelson, *An Introduction to Behavioral Endocrinology*, 2nd ed.

For the (very difficult) bible of the field:

P. Larsen et al., *Williams Textbook of Endocrinology*, 10th ed.

Questions to Consider:

- 1. What are ways in which the brain can regulate hormone release?
- 2. What are steps that could give rise to differences between two individuals in the functioning of a particular endocrine system?

Figure 8a

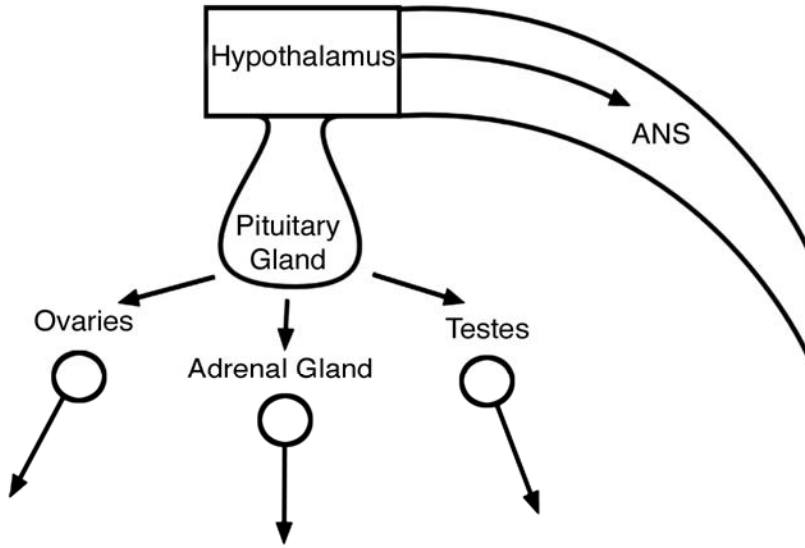

Figure 8b

Examples of Endocrine Regulation

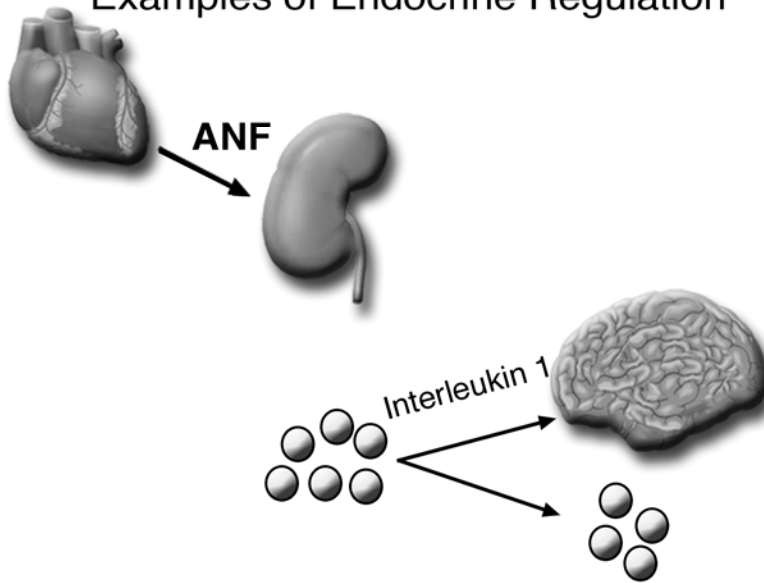
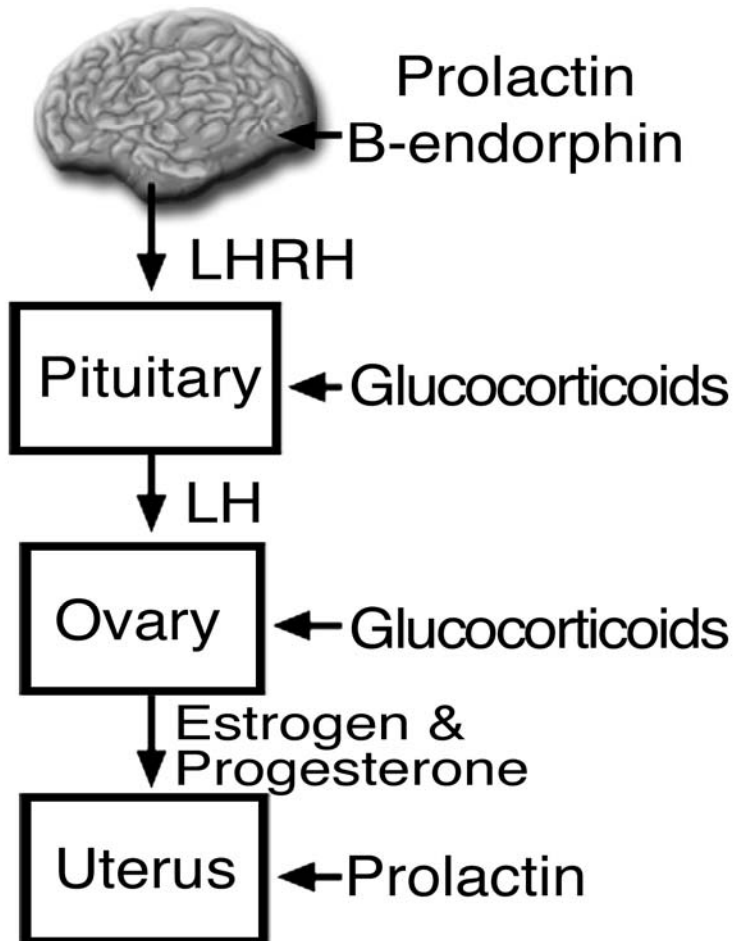

Figure 8c

Why Female Mammals Are Less Likely to Ovulate under Stress



Lecture Nine

The Regulation of the Brain by Hormones

Scope: This lecture examines the other half of the endocrine cycle: how hormones regulate the brain. This lecture will focus on both the *organizational* effects of hormones (which is how exposure to hormones early in life, beginning with fetal life, can alter the structure and function of the brain forever after) and the *activational* effects of hormones (which is how hormones can alter brain function on a much shorter timespan).

Outline

- I. Hormones have effects on cells, including cells in the brain.
 - A. Both neurons and glial cells have hormone receptors.
 - B. Hormones can alter protein function and synthesis in the brain, just as they do throughout the rest of the body.
 - C. Hormones can alter neurotransmitter actions in the brain. (Figure 9a)
 1. Dopamine is a neurotransmitter of pleasure in the brain.
 2. Steroid hormones called glucocorticoids are released during stress, and these hormones have an effect on dopamine release.
 - a. During short-term stress (stimulation), a transient rise in glucocorticoid levels occurs, resulting in increased synaptic release of dopamine. This can produce pleasurable effects. LTP is enhanced as well.
 - b. During long-term stress, however, a chronic rise in glucocorticoid levels occurs; thus, the dopamine neurons are depleted, leading to anhedonia, or the inability to feel pleasure.
 - D. Hormones can also alter the plasticity of synapses.
 1. Glucocorticoid levels affect the hippocampus and the amygdala differently.
 - a. A transient rise in glucocorticoid levels in the hippocampus brought on by short-term stress enhances LTP, while sustained glucocorticoid exposure in the hippocampus can disrupt LTP.
 - b. On the other hand, chronic stress enhances LTP in the amygdala, thereby enhancing the ability of the amygdala to “file away” memories of trauma.
 - c. This factor might explain free-floating anxiety, in which the hippocampus does not recall an explicit traumatic memory, but the amygdala recognizes the source of the trauma and activates the sympathetic nervous system.
 2. Estrogen is another hormone that enhances LTP in the hippocampus.
 - E. Hormones can change the structure of neural networks, causing neurons to grow more elaborate dendritic branches or to shrivel up.
 1. Chronic stress and the resulting chronic glucocorticoid exposure cause atrophy of hippocampal neurons, thus inhibiting learning.
 2. Chronic stress and the resulting chronic glucocorticoid exposure cause expansion of dendritic branches in the amygdala, thus increasing anxiety.
 3. Higher estrogen levels cause the growth of new dendritic branches in hippocampal neurons, thus enhancing learning and memory.
 - F. Hormones can affect the birth and death of neurons. The discovery of adult *neurogenesis* is an exciting new finding in neurobiology.
 1. Estrogen enhances the birth of new neurons in the adult brain, while glucocorticoids inhibit such neurogenesis.
 2. Estrogen makes neurons more likely to survive a neurological insult, while glucocorticoids do the opposite in response to such an insult.
 - G. Hormones can influence how the brain regulates the body and behavior.

1. For example, it used to be thought that glucose levels in the bloodstream alone controlled our appetites.
 2. Now it is known that an array of hormones released by the gastrointestinal tract, fat cells, liver, and pancreas regulate appetite.
- II. A theme that runs through behavioral neuroendocrinology is that hormones may “cause” some behaviors, such as aggression, to occur. Instead, however, hormones alter a preexisting tendency for the behavior to occur in the context of interaction with the environment. This notion will be studied more in depth in the lectures on aggression.

Further Reading:

For two excellent texts:

J. Becker, M. Breedlove, D. Crews, and M. McCarthy, *Behavioral Endocrinology*, 2nd ed.

R. Nelson, *An Introduction to Behavioral Endocrinology*, 2nd ed.

For the (very difficult) bible of the field:

P. Larsen et al., *Williams Textbook of Endocrinology*, 10th ed.

Questions to Consider:

1. What would brain function be like if hormones could not get access to the brain?
2. Could one claim (in a courtroom, for example) that a behavior was caused by hormones?

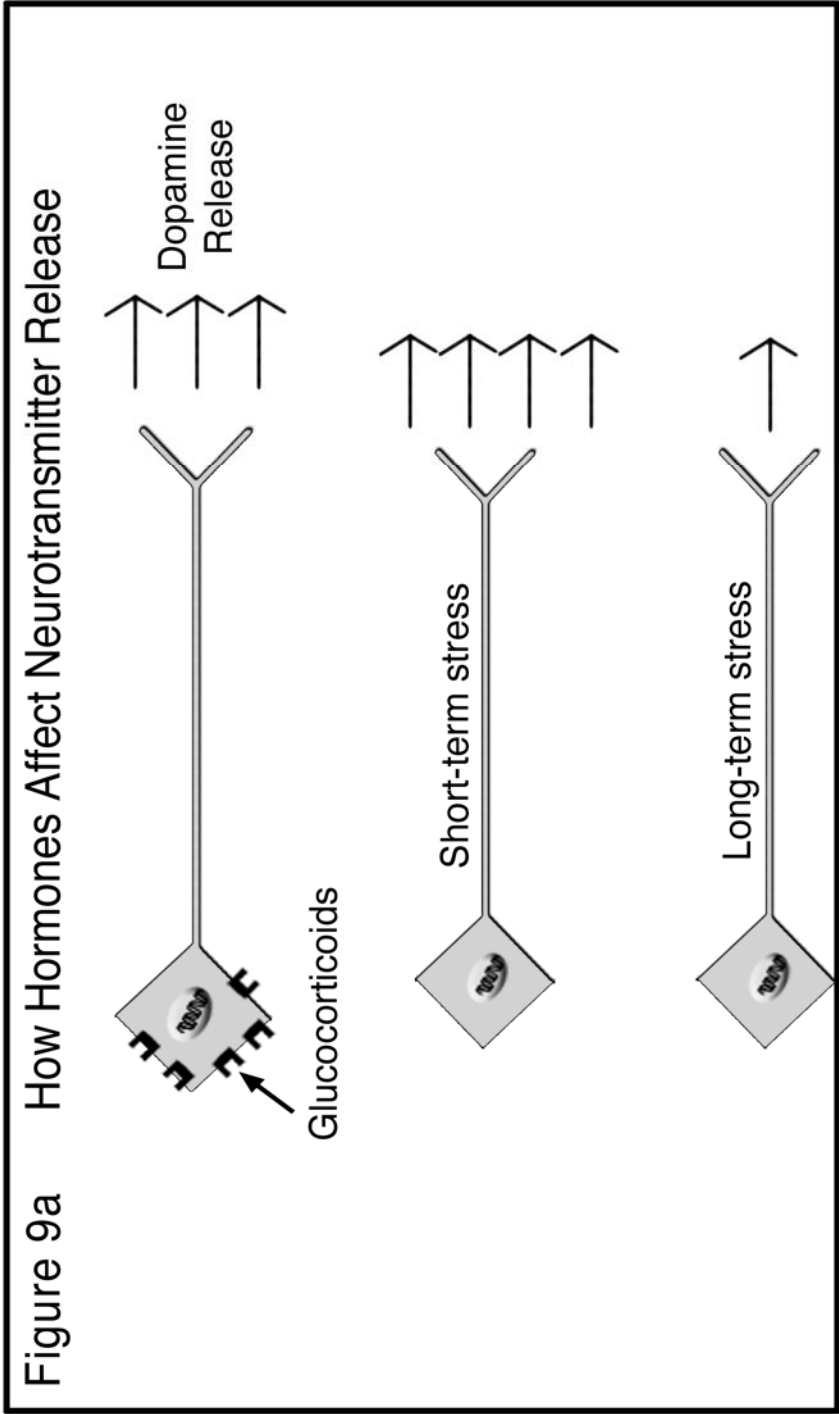

Module IV

Evolution and the Neurobiology of Behavior

Module Scope:

This module is the first of a series that expands the focus of the course, examining how the brain is shaped and regulated. It considers the evolution of the brain and behavior. First, we review the mechanisms of evolution, then we look at how those mechanisms might be relevant to the evolution of behavior. In Lecture Eleven, we then consider a variety of initially puzzling examples of social behavior in the light of evolutionary principles. Finally, in Lecture Twelve, we review the evolution of competition and how the brain functions under different settings of competition.

Lecture Ten

The Evolution of Behavior

Scope: We all understand the evolutionary biology of how, for example, the giraffe evolved its long neck as an adaptive trait. This lecture introduces the idea that behavior and the brain that produces behavior have also evolved, sculpted toward adaptive features by natural selection. Then, the lecture provides an overview of the various ways in which species can maximize the number of copies of their genes passed on to the next generation through behavioral means.

Outline

- I. The evolutionary biology taught in high school was built around certain key points that help to explain such phenomena as how giraffes evolved long necks.
 - A. The first key point is the inheritance of traits across generations; that is, traits can be passed on from one generation to the next.
 - B. The second key point is the variability in those heritable traits among individuals. In modern genetic molecular terms, mutations in genes can be passed from one generation to the next.
 - C. The third key point is known as *differential fitness*; that is, some versions of those genetic variants are more adaptive, more fit, than others. (Figure 10a)
 1. Organisms with maladaptive mutations do not reproduce; they do not survive, and therefore, they do not pass on copies of their genes.
 2. Organisms having beneficial mutations, however, do reproduce; thus, the new version of a trait becomes more plentiful.
 3. Intrinsic to this key point is the debunking of a great urban legend of evolution, which is *survival of the fittest*. Instead, the key is *reproduction of the fittest*.
- II. How did behavior evolve?
 - A. The notion exists that behavior is sculpted by evolution, by the same forces of nature that influenced the length of our necks and the functioning of our hearts and kidneys.
 - B. That notion leads, however, to the inflammatory issue of heritability of behavior: the issue of whether a certain behavior has a genetic component.
- III. Building block #1 in considering the evolution of behavior is *individual selection*.
 - A. The old notion of group selection, that is, the idea that animals behave “for the good of the species” and that behaviors are driven by ways to increase the likelihood of the species surviving and multiplying, has been proven wildly incorrect.
 - B. Instead, by the early 1960s, the concept of individual selection was accepted.
 1. This idea proposed that evolution is not about animals behaving for the good of the species but, rather, behaving to optimize the number of copies of their own genes to pass on to the next generation.
 2. This idea brought about the oversimplified and somewhat erroneous notion of the *selfish gene*: the idea that a gene’s purpose is to maximize one’s own ability to reproduce and to pass on copies of one’s own genes.
 3. Another way to illustrate this idea is a quote from an early evolutionist, Samuel Butler: “A chicken is just an egg’s way of making another egg.”
 - C. A rather grim example of the logic of individual selection is competitive infanticide, as seen in a number of species, even those as endangered as the gorilla.
- IV. Building block #2 in considering the evolution of behavior is *kin selection (inclusive fitness)*.
 - A. What does it mean to be related to someone? It means you share genes with that individual.

- B. Kin selection is a way to help your relatives reproduce as much as they can—passing on copies of your genes by helping relatives.
 - C. Degrees of relatedness on a genetic level come into play here because we are “more related” to some individuals than others. For example, full siblings are closer genetically than half siblings; a parent is closer genetically to a child than is a grandparent. In short, the more steps away relatives are from one another, the fewer genes they share in common.
 - D. One of the implications of kin selection is an obsession with kinship. For the most part, data support the logic that we are cooperative with relatives as a function of how related they are to us; hence the quote of evolutionary geneticist J. B. S. Haldane: “I will lay down my life for two brothers or eight cousins.”
 - E. Some examples of kin selection in the animal world include adelphic polyandry, food sharing in inbred species, and parent-offspring conflict.
 1. *Polyandry*, in which a single female mates with more than one male, occurs fairly rarely in the animal kingdom and among humans. However, when it does occur, it is often *adelphic polyandry*, in which the males are brothers.
 2. Many studies show that the degree of relatedness is an accurate predictor of how much one animal shares food with another.
 3. Parent-offspring conflict stems from the idea that whereas a parent wants to balance the survival of current offspring with that of future offspring, those current offspring want more care than the parent cares to offer. For example, conflict may occur between a mother baboon who wishes to wean her year-old offspring so that she can ovulate and possibly produce another, while that young baboon wants to continue nursing.
- V. Building block #3 in considering the evolution of behavior is *reciprocal altruism*.
- A. This notion is based on the concept that many hands make the task light. Such cooperation ensures the distribution of risk- and food-sharing among hunters.
 - B. Reciprocity is very common in all sorts of social species, even among nonrelatives.
 - C. However, species that exhibit such patterns of cooperation must possess certain characteristics.
 1. Reciprocity will work only in a species with stable social groups.
 2. The species involved must live long enough to benefit from the cooperation.
 3. The members of the species must have enough social intelligence to recognize other members of their species.
 - D. In games of reciprocal altruism, which we will discuss in Lecture Twelve, individuals will try to cheat whenever they can; thus, another requirement is vigilance against cheaters.
 - E. Potential examples of reciprocal altruism include blood-sharing among vampire bats and coalitions among male baboons.

Further Reading:

For good introductions to evolution and the neurobiology of behavior:

D. Barash, *The Survival Game: How Game Theory Explains the Biology of Cooperation and Competition*.

A. Brown, *The Darwin Wars: The Scientific Battle for the Soul of Man*.

M. Ridley, *The Origins of Virtue: Human Instincts and the Evolution of Cooperation*.

For the most magisterial book on the subject:

E. O. Wilson, *Sociobiology: The New Synthesis, Twenty-fifth Anniversary Edition*.

Questions to Consider:

1. How has evolutionary thought shifted from an emphasis on groups to an emphasis on individuals?
2. What are the ways in which modern evolutionary thought is not merely about selection at the individual level?

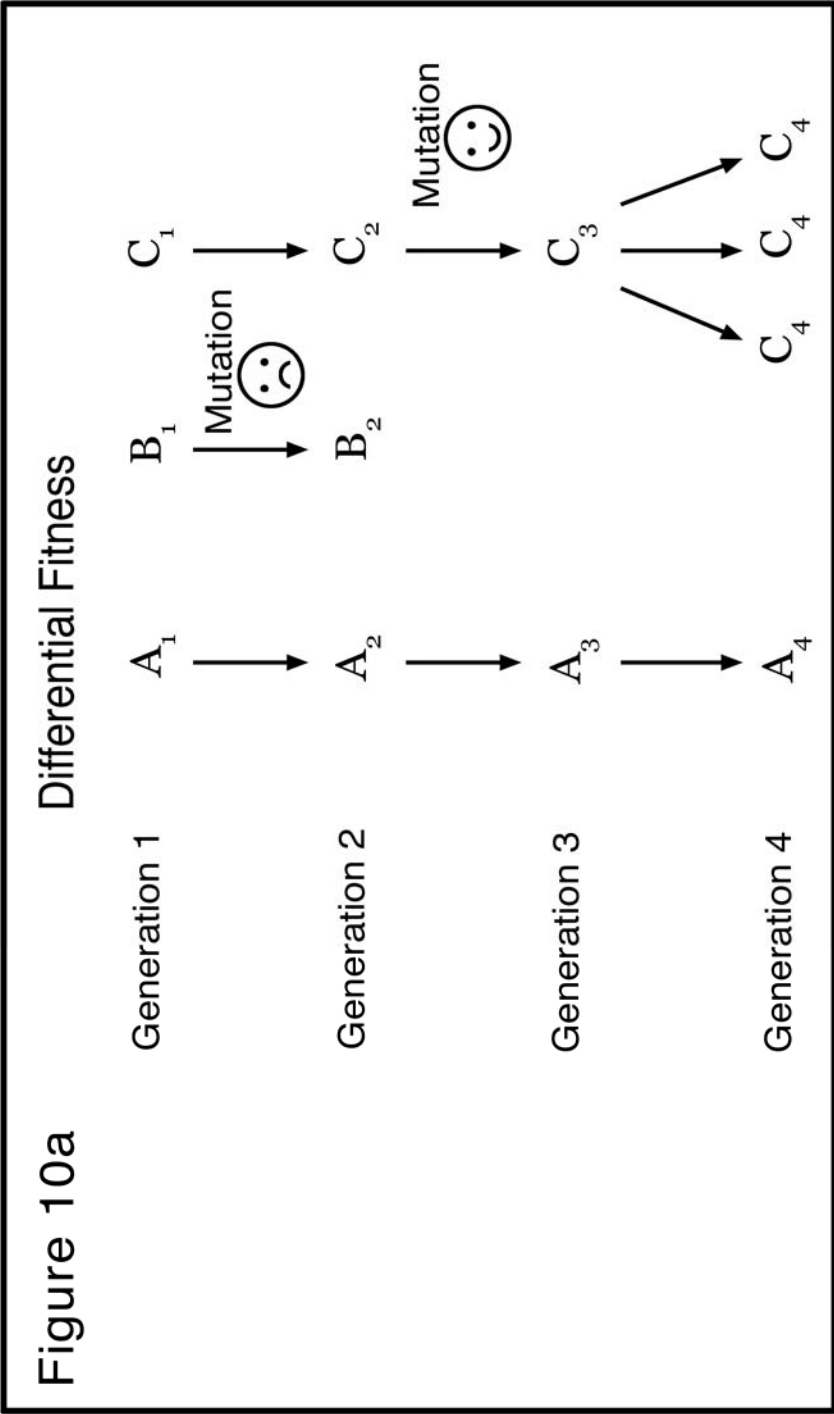

Lecture Eleven

The Evolution of Behavior—Some Examples

Scope: Lecture Ten introduced the principles of the evolution of behavior. This lecture will explore how that conceptual framework helps explain, and even predict, social behavior in numerous species that vary in how aggressive they are, whether they are monogamous or polygamous, whether males participate in childcare, and so on. Throughout this lecture, links will be made to previous lectures to establish how the evolution of these behaviors translates into the neurobiology of these behaviors.

Outline

- I. How can we successfully predict the social structure of an entire species (tournament versus pair-bonding) based on just one fact? Figure 11a lists the cluster of traits common to each type of species.
- II. Imprinted genes and intersexual competition also play roles in evolutionary biology. (Figure 11b)
 - A. Mendel theorized that a gene is a gene, regardless of which parent you inherited it from.
 - B. Imprinted genes—genes that produce different outcomes in offspring depending on which parent they come from—have been discovered to be an exception to the laws of Mendelian heredity. For example, during fetal life, some male-derived genes push for more fetal growth, while female-derived genes favor the opposite.
 - C. The logic of imprinted genes is that in polygamous species, males and females have different investments in any given pregnancy. The male would like the female to expend all her energy raising his offspring, even at the expense of her ability to reproduce again. The female, however, wishes to balance her investment in her current offspring with her investment in her future reproductive potential.
 - D. The effects of imprinted genes in the brain on behavior after birth provide a marked contrast, with male-derived genes favoring more feeding and growth and female-derived genes the opposite, trying to slow the growth down.
 - E. Generally, polygamous species have large numbers of imprinted genes, whereas monogamous species have virtually none.
 - F. Humans are neither a classic pair-bonding species nor a classic tournament species; we are somewhere in between. Therefore, we have some imprinted genes.
- III. Fruit flies and sperm competition also illustrate this intersexual competition.
 - A. Numerous male fruit flies mate with the female; thus, sperm from many different males is inside the female fruit fly's body.
 - B. The male sperm release toxins in an effort to kill its competitors' sperm. These toxins are damaging to the female fruit fly.
 - C. However, female fruit flies' bodies have evolved so that they now produce detoxifying defenses.
- IV. Kin-based defense systems also illustrate the notion of kin selection.
 - A. When female vervet monkey A attacks female vervet monkey B for “no reason,” the underlying cause for the attack can actually be that the child of monkey B had attacked the child of monkey A.
 - B. Patterns of aggression that closely follow the lines of kin selection are another way to ensure that the maximum number of copies of one's genes is passed on to the next generation.

Further Reading:

For good introductions to evolution and the neurobiology of behavior:

D. Barash, *The Survival Game: How Game Theory Explains the Biology of Cooperation and Competition*.

A. Brown, *The Darwin Wars: The Scientific Battle for the Soul of Man*.

M. Ridley, *The Origins of Virtue: Human Instincts and the Evolution of Cooperation*.

For the most magisterial book on the subject:

E. O. Wilson, *Sociobiology: The New Synthesis, Twenty-fifth Anniversary Edition*.

Questions to Consider:

1. How can an infant be viewed as the outcome of intersexual evolutionary competition?
2. What is the role of kinship in making sense of the evolution of behavior?

Figure 11a

Tournament

Polygamous

No Paternalism

Low ♂ Pickiness

High ♂♂ Aggressor, Variance

High Sexual Dimorphism

♀ Seek Good Sperm

No Cuckoldry

Pair Bond

Monogamous

High Paternalism

High ♂ Pickiness

Low ♂♂ Aggressor, Variance

Low Sexual Dimorphism

♀ Seek Good Fathers

Cuckoldry

Figure 11b

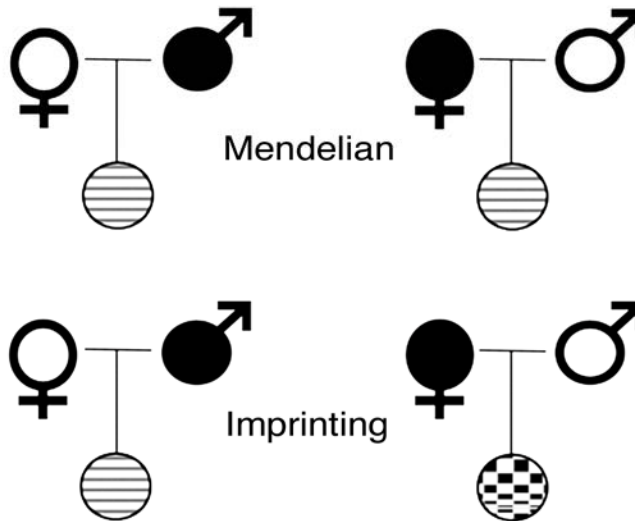

Lecture Twelve

Cooperation, Competition, and Neuroeconomics

Scope: This lecture first considers a special topic in the evolution of behavior, namely, the balance between competitive and cooperative behaviors among members of the same species. The formal analysis of such behavior, called *game theory*, is introduced and framed in both the context of the evolution of such strategizing and the sort of brains that can accomplish such strategizing. The lecture finishes this section on evolution with a brief consideration of the issues that are unique to making sense of the evolution of human social behavior and its underlying neurobiology.

Outline

- I. One of the three building blocks of evolutionary biology is reciprocal altruism or cooperation, which was covered in Lecture Ten.
 - A. Cooperation is evolutionarily desirable, improving conditions in many settings.
 - B. The bigger advantage is gained, however, when the other individual cooperates while you cheat. However, if you both cheat, the outcome can be really bad.
 - C. Thus, the question arises: When do you cooperate and when do you cheat?
 - D. This question is at the heart of a relatively new field called *game theory*, which originated in the area of economics.
- II. Game theory applications to evolutionary biology are manifested in a game called the *Prisoner's Dilemma*. (Figure 12a)
 - A. Its basic design is one of cooperation or defection: Successfully cheating is more rewarding than mutually cooperating, which is more rewarding than no one cooperating, which is more rewarding than cooperating with a cheater.
 - B. Economist Robert Axelrod's famous round-robin Prisoner's Dilemma tournament led to the emergence of the tit-for-tat strategy: losing the battles but winning the war by being cooperative, clear, retributive, and forgiving.
 - C. The vulnerability of the tit-for-tat strategy lies in signal errors, in other words, if communication between two sides is unclear.
 - D. Forgiving tit-for-tat is a derived strategy that comes about when a mistake in communication is introduced into the system. After the wrong signal is given, a few rounds of cheating ensue, then one player "forgives," and cooperation is reestablished.
- III. Establishing cooperation in such games as the Prisoner's Dilemma can prove challenging.
 - A. The problem exists of the disadvantage for the first player to make an altruistic gesture; that player will always be one step behind.
 - B. One solution is kin selection in isolated, inbred populations. (Figure 12b)
 1. A small group that has become separated from a greater group tends to inbreed, with members becoming more related to each other; in this way, cooperation begins, initially driven mostly by kin selection.
 2. When that small group, called the *founder population*, later rejoins the main population, that nucleus of cooperators influences the rest of the population to cooperate.
 - C. Another solution lies in repeated interactions with the same player and the shadow of the future. In this case, players realize that, although cheating may offer a short-term advantage, it is better to cooperate in view of future rounds because the tit-for-tat strategy is about losing battles but winning the war.
 - D. Another variable to consider is open-book play and reputation; that is, the ability for players to see what another's strategy has been in other games.

- E. Still another variable is the interspersing of multiple games, in which the level of cooperation in one game can influence the level of cooperation in another, resulting in an equilibrium state of cooperation in both games. (Figure 12c)
 - F. Punishment is another great impetus for cooperation.
 1. Cooperation emerges when punishment is allowed in single-round, closed-book games.
 2. Cooperation also flourishes when there is the potential for “altruistic punishment.” That is, A does something bad to B, and C, as a disinterested outsider, punishes A for doing so.
 3. Taken one step further, secondary punishment is introduced, wherein both cheaters and anyone who knowingly fails to punish a cheater are punished. Honor codes at military schools and universities engender cooperation through the threat of such secondary punishment.
 - G. Choice as to whom to play with out of a pool of potential partners enables players to select for cooperation.
 - H. Choice as to whether you play or not is another option.
- IV. Other games in the repertoire of game theory include Chicken, the Ultimatum Game, and the Battle of the Sexes.
- V. Intrinsic to all this behavior in games is something obvious to just about anyone: Humans do not always make rational economic choices; we are not rational in reciprocal altruistic interactions.
- VI. Studying the evolution of reciprocity has culminated in the development of the field of neuroeconomics: imaging the brain during game playing and decision making. Some classic findings have come about from this imaging.
- A. The outcome in a Prisoner’s Dilemma game that is revealed through brain imaging to be the most powerful stimulus of the dopamine-releasing pleasure pathway is a surprise, to some, at least: cooperation between both players.
 - B. In another scenario, when a choice must be made between a cheap, fast payoff and a much greater reward later, the frontal cortex, which plays a central role in gratification postponement and resistance of the temptation of a quick, small payoff, is shown to be more activated.
 - C. The Runaway Trolley quandary in philosophy is another classic problem.
 1. You have two choices to save lives on a runaway trolley that is racing down a track about to hit and kill five people: Either you can pull a lever that will divert the trolley to another track where it will kill only one person *or* you can push one large person onto the track and that will stop the trolley before it hits the five people. With either choice, you will kill one person to save five.
 2. We tend to make completely different decisions depending on the emotional salience of how a problem is presented. In this quandary, most people choose to pull the lever.
 3. When a person is contemplating pulling the lever, the frontal cortex activates. But when the person is contemplating pushing someone off the trolley to his death, the limbic system activates. Cortical versus limbic activation is identified, depending on the emotionality with which a problem is framed.

Further Reading:

For good introductions to evolution and the neurobiology of behavior:

D. Barash, *The Survival Game: How Game Theory Explains the Biology of Cooperation and Competition*.

A. Brown, *The Darwin Wars: The Scientific Battle for the Soul of Man*.

M. Ridley, *The Origins of Virtue: Human Instincts and the Evolution of Cooperation*.

For the most magisterial book on the subject:

E. O. Wilson, *Sociobiology: The New Synthesis*, Twenty-fifth Anniversary Edition.

Questions to Consider:

1. How can it be that cooperators in the Prisoner’s Dilemma lose each battle with cheaters but win the war?
2. What are the circumstances that bias toward the emergence of cooperation?

Figure 12a Game Theory, The Prisoner's Dilemma

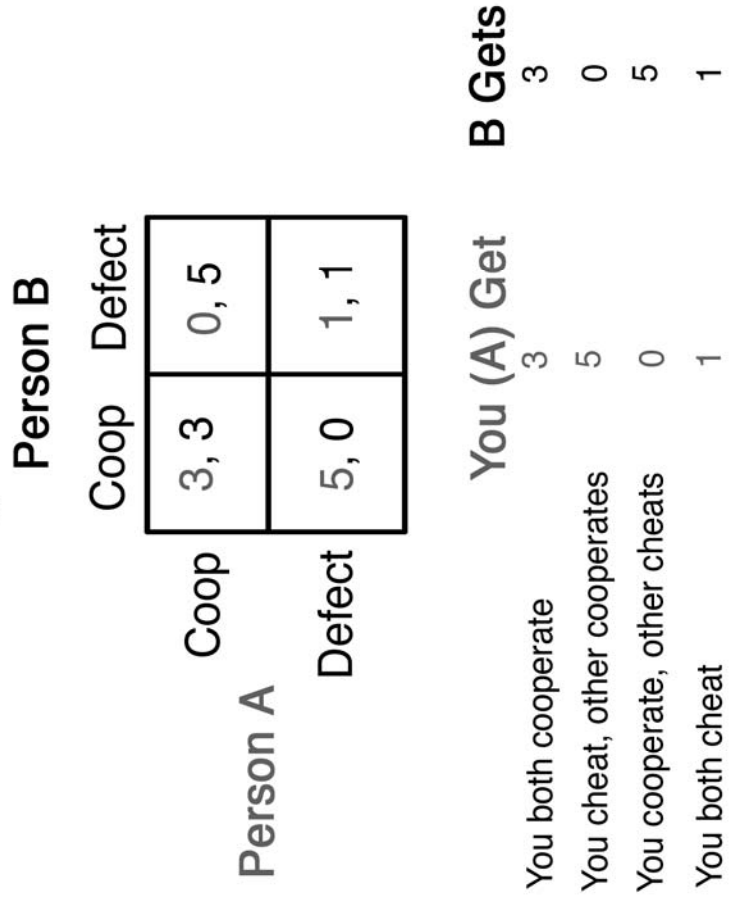

Figure 12b

Special Circumstances That Select for Cooperation

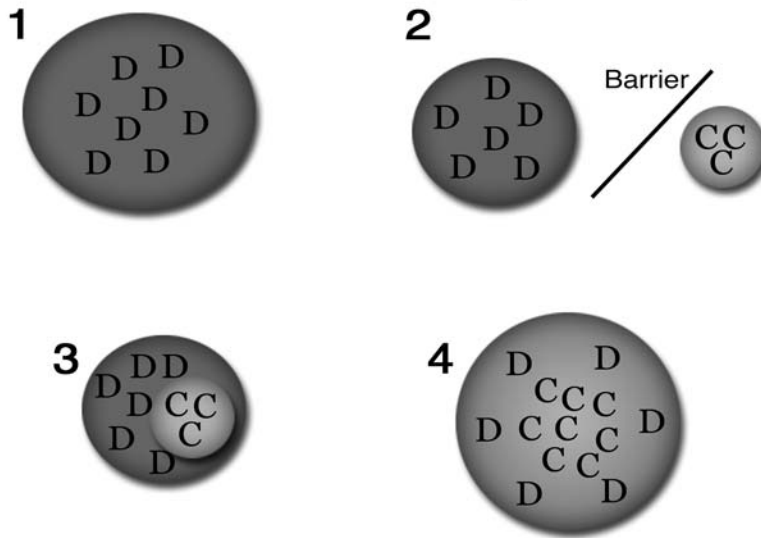
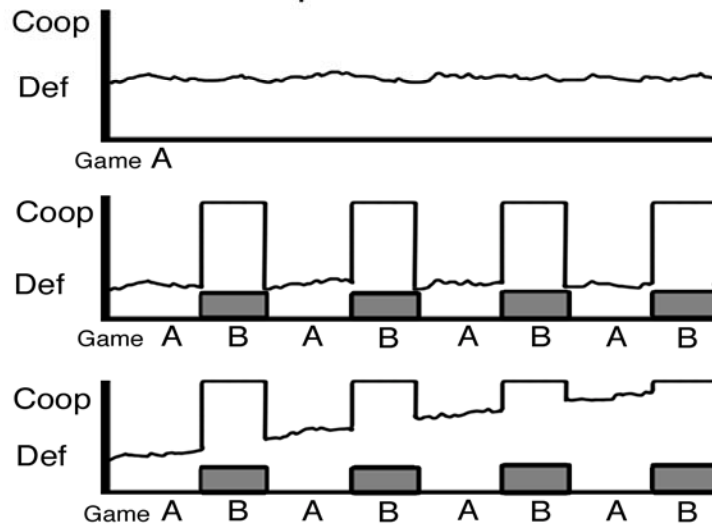

Figure 12c

Multiple Games



Glossary

Acetylcholine: A neurotransmitter whose functions include release from the ends of the final neurons in the parasympathetic nervous system.

Action potential: The burst of electrical excitation that shoots down the axon when a neuron is sufficiently stimulated via its dendrites. (Contrast with **resting potential**.)

Activational effects of hormones: A hormonal effect (typically in adults) that has an immediate consequence. (Contrast with **organizational effects**.)

Amino acids: The building blocks of proteins; about 20 different kinds, akin to letters, exist. Unique sequences of amino acids are strung together to form a particular protein. That sequence determines the folded shape of that protein and, thus, its function.

Amygdala: A limbic structure with a key role in aggression and fear, as well as sexual arousal in males.

Anabolic hormones: A rather imprecise term typically denoting androgenic (testosterone-related) hormones.

Androgens: A class of steroid hormones, including testosterone, with roles in aggression and sexual behavior in both sexes but most notably in males. (See also **anabolic hormones**.)

Autonomic nervous system (ANS): A series of neural pathways originating in the hypothalamus, hindbrain, and brainstem and projecting throughout the body; it regulates all sorts of nonconscious, automatic physiological changes throughout the body. The ANS consists of the sympathetic and parasympathetic nervous systems.

Axon hillock: The beginning of the axon; this is the point where small excitatory inputs from various dendrites are summated and, if of a sufficient magnitude, trigger an action potential.

Axon terminal: The part of the neuron from which neurotransmitters are released.

Axon: The part of the neuron that sends signals to other neurons. (Contrast with **dendrite**.)

Behaviorism: The school of American psychology that posited that the incidence of all behaviors can be shaped by reward and punishment and that these patterns are sufficiently universal that virtually any vertebrate species can be a stand-in for learning principles in humans. (Contrast with **ethology**.)

Benzodiazepines: Compounds that reduce anxiety. Synthetic versions include Valium and Librium; naturally occurring versions are found within the brain, but their chemical structure is poorly understood.

Central nervous system: The brain and spinal cord. (Contrast with **peripheral nervous system**.)

Chromosome: A long, continuous sequence of genes. Metaphorically, the genome is like a massive phone book of information, with each message being a single gene made up of DNA letters. Because of its size, it is broken into separate volumes—each volume being a chromosome.

Compulsion: See **obsessive-compulsive disorder**.

Congenital adrenal hyperplasia: A disorder in which female fetuses are exposed to high levels of androgens (male sex hormones).

Dendrite: The part of the neuron that receives signals from other neurons. Dendrites tend to come in the form of highly branched cables coming from the cell body of a neuron. (Contrast with **axon**.)

Deoxyribonucleic acid (DNA): the nucleic acid that carries the genetic information of the cell.

Dopamine: A neurotransmitter whose functions include a role in sequential thought (such that abnormal dopamine levels are associated with the disordered thought of schizophrenia), the anticipation of pleasure, and aspects of fine motor control.

Endocrinology: The study of hormones.

Epinephrine (a.k.a. adrenaline): Both a neurotransmitter throughout the brain and a hormone released in the adrenal gland during stress as a result of activation of the sympathetic nervous system.

Estrogen: A class of female reproductive hormones.

Ethology: The study of the behavior of animals in their natural environments. (Contrast with **behaviorism**.)

Excitatory neurotransmitter: See **neurotransmitter**.

Exon: The stretch of DNA coding for a gene can occasionally be broken into separate parts, called *exons*. The intervening stretches of DNA, which do not code for anything, are called **introns**.

Fixed action pattern: A term in ethology referring to a behavior that occurs in a fairly intact form even in the absence of experience or learning but can be further refined by experience.

Frontal cortex: A recently evolved region of the brain that plays a central role in executive cognitive function, decision making, gratification postponement, and regulation of the limbic system.

Frontotemporal dementia: A neurological disorder (most often due to a specific mutation) in which disintegration of the frontal cortex occurs.

Game theory: A field of mathematics formalizing strategies used in games of cooperation and/or competition.

Gene: A stretch of DNA that designates the construction of one protein.

Gene-environment interaction: The virtually universal phenomenon in which the effect of a gene varies as a function of the environment in which it is transcribed.

Gene transcription: The process of a gene being “read” and transcribed into RNA.

Glial cells: An accessory type of cell found in the nervous system. Glial cells support neuronal function by insulating the axons of neurons, indirectly supplying neurons with energy, scavenging dead neurons, and removing toxins from the extracellular space around neurons. (Contrast with **neurons**.)

Glucocorticoids: A class of steroid hormones secreted during stress. They include cortisol (a.k.a. hydrocortisone) and synthetic versions, such as prednisone and dexamethasone.

Glutamate: An excitatory neurotransmitter with critical roles in learning and memory. An excess of glutamate induces *excitotoxicity*, a route by which neurons are killed during various neurological insults.

Gradualism: The theory that evolutionary changes occur constantly, in small, incremental steps. (Contrast with **punctuated equilibrium**.) Gradualism produces microevolutionary changes.

Group selection: The mostly discredited notion that evolution works on groups rather than individuals and, thus, that the evolution of behavior can be understood in the context of animals behaving “for the good of the species.” (Contrast with **individual selection**.)

Hippocampus: A brain region within the limbic system that plays a central role in learning and memory.

Hormones: Blood-borne chemical messengers between cells.

Hypothalamus: A limbic structure that receives heavy inputs from other parts of the limbic system; plays a central role in regulating both the autonomic nervous system and hormone release.

Imprinted genes: Genes whose function differs depending on whether they are inherited from the father or mother. Imprinting of genes in this context should not be mistaken with the ethological notion of imprinting.

Imprinting: An ethological concept in which a permanent change in behavior occurs rapidly, in the absence of experience (for example, the imprinting of newborn birds onto their mother).

Individual selection: A contemporary notion in evolutionary biology that natural selection works mostly at the level of the individual and, thus, that the evolution of behavior can be understood in the context of animals behaving to maximize the number of copies of their genes passed on to the next generation. (Contrast with **group selection**.)

Inhibitory neurotransmitter: See **neurotransmitter**.

Innate releasing mechanism (IRM): An ethological term referring to the physiological mechanisms by which a stimulus (for example, a releasing stimulus) triggers a behavior (for example, a fixed action pattern).

Intron: A stretch of DNA that does not actually code for a gene but, instead, breaks up a gene into separate parts (called **exons**).

Jumping genes: See **transposable genetic elements**.

Kin selection: A contemporary notion in evolutionary biology that an individual can maximize the number of copies of his or her genes that are passed on by aiding the reproduction of relatives.

Klüver-Bucy syndrome: A set of behavioral changes, including elevated levels of aggression, resulting from removal of large parts of the limbic system, including the amygdala.

Limbic system: A part of the brain most strikingly involved in emotion. Some major parts include the hippocampus, amygdala, hypothalamus, and septum.

Long-term potentiation (LTP): A phenomenon in which the strength of synaptic communication between two neurons is enhanced in a persistent manner; thought to be a cellular analog of learning.

Mutation: An error in the copying of a gene. Classically, mutations can take three forms: In *point mutations*, a letter in the DNA code is misread as a different letter. In *deletion mutations*, a letter is entirely lost. In *insertion mutations*, an extra letter is inserted.

Myelin sheath: The insulation, made from glial cells, that wraps around the axons of neurons. Myelin allows action potentials to travel down the axon more quickly.

Neurobiology: The study of the nervous system.

Neuroeconomics: A new field examining the brain bases of economic decision making.

Neuroendocrinology: The study of the interactions between the nervous system and hormones.

Neuroethology: The study of the neural mechanisms mediating the naturalistic behavior of animals.

Neurons: The primary cells of the nervous system. (Contrast with **glial cells**.)

Neurotransmitter: Chemical messengers released from axon terminals as a result of an action potential; these travel across the synapse and bind to specific receptors on the postsynaptic side, thereby changing the electrical excitation of the second neuron. Excitatory neurotransmitters increase the likelihood that the next neuron will have an action potential, whereas inhibitory neurotransmitters decrease the likelihood.

Nongenetic inheritance: A phenomenon in which some event in the fetus changes the function of that individual when she is an adult, and that change produces a similar change in her own eventual fetus. Thus, a trait can be passed on for generations but in a way that does not involve genes and classic inheritance.

Norepinephrine (a.k.a. noradrenaline): A neurotransmitter whose functions include release from the ends of the final neurons in the sympathetic nervous system, as well as a role in depression (with, most likely, a depletion occurring).

Obsession: See **obsessive-compulsive disorder**.

Obsessive-compulsive disorder: A neuropsychiatric disorder categorized by virtually ceaseless intrusions of distracting, disturbing, and repetitive thoughts (*obsessions*) and by irresistible urges to carry out pointless, ritualistic behaviors (*compulsions*).

Organizational effects of hormones: Hormonal effects early in life (for example, in the fetus) that do not have an immediate consequence but that cause changes in the body's response to some hormone during adult life. (Contrast with **activational effects**.)

Pair-bonding species: Species in which mating tends to be monogamous. (Contrast with **tournament species**.)

Parasympathetic nervous system (PNS): The half of the autonomic nervous system associated with calm, vegetative function. (Contrast with **sympathetic nervous system**.)

Peptide hormones: A class of hormones made from amino acids. They predominately work by changing the activity of preexisting proteins.

Peripheral nervous system: Neurons and associated glial cells that occur outside the brain or spinal cord. (Contrast with **central nervous system**.)

Pituitary: The gland underneath the hypothalamus that releases an array of hormones under the control of the brain.

Plasticity: The general notion of aspects of neural function changing over time.

Prisoner's Dilemma: A classic game theory scenario.

Progesterone: A class of female reproductive hormones.

Promoters: Stretches of DNA that do not code for a gene but serve as the on-off switch for a gene to be transcribed.

Protein: Long strings of amino acids. Unique sequences of amino acids are strung together to form a particular protein. That sequence determines the folded shape of that protein and, thus, its function.

Pseudokinship: A form of cultural manipulation by which people are led to view other individuals as more related to them than they actually are.

Pseudospeciation: A form of cultural manipulation by which people are led to view other individuals as less related to them than they actually are.

Punctuated equilibrium: The theory that evolution consists of long periods of stasis, when there are no evolutionary changes, interspersed with periods of rapid and dramatic change. (Contrast with **gradualism**.) Punctuated equilibrium produces macroevolutionary changes.

Releasing stimulus: An ethological term referring to the sensory stimulus in an environment that triggers a behavior.

Resting potential: The state of electrical excitation in a neuron when it is quiescent. (Contrast with **action potential**.)

Ribonucleic acid (RNA): An intermediate form of information. A strand of RNA is made under the direction of a single gene; that stretch of RNA, in turn, contains the information for the stringing together of amino acids into a protein.

RNA translation: The process of RNA being "read" and translated into protein.

Schizotypal personality disorder: A neuropsychiatric disorder, on a genetic continuum with schizophrenia, characterized by social withdrawal, overly concrete thought, and metamagical beliefs.

Selective serotonin reuptake inhibitors (SSRIs): Drugs such as Prozac that block the removal of serotonin from the synapse. Insofar as they lessen the symptoms of depression, this implies that depression involves a shortage of dopamine.

Septum: Limbic structure with a key role in inhibiting aggression.

Serotonin: A neurotransmitter whose functions include a role in aggression, sleep onset, depression, and impulsivity.

Spatial summation: When an action potential is triggered thanks to enough separate dendritic inputs being stimulated all at once. (Contrast with **temporal summation**.)

Steroid hormones: A class of hormones made from steroid precursor molecules that include estrogens, progestins, androgens, glucocorticoids, and mineralocorticoids. They predominately work by changing genomic events in cells.

Sympathetic nervous system (SNS): The half of the autonomic nervous system associated with arousal and emergency physiological responses. (Contrast with **parasympathetic nervous system**.)

Synapse: The space between an axon terminal and the dendritic spine of the next neuron.

Synaptic plasticity: The concept of the strength of communication between two neurons changing over time.

Temporal personality disorder: A neuropsychiatric disorder associated with temporal lobe epilepsy, characterized by perseverative behavioral patterns, aversion to novelty, obsessive writing (hypergraphia), and an intense interest in religious and philosophical subjects.

Temporal summation: When an action potential is triggered thanks to the same subthreshold dendritic input being stimulated over and over. (Contrast with **spatial summation**.)

Testosterone: A subtype of androgen.

Theory of mind: The understanding that other individuals have different thoughts and knowledge than you; most frequently used as a term in child development.

Thrifty metabolism: The idea that malnutrition during the prenatal environment causes metabolic “programming” so that for the rest of the individual’s life, there is more efficient storage of nutrients.

Tourette’s syndrome: A neuropsychiatric disorder categorized by uncontrolled outbursts of scatology, tics, and utterances.

Tournament species: Species in which mating tends to be highly polygamous and involves high levels of male-male aggression and competition. (Contrast with **pair-bonding species**.)

Transcription factors: Messengers (often proteins) that bind to promoters and turn genes on or off.

Transposable genetic elements: Stretches of DNA that can be moved around; also called *jumping genes*.

Ventral tegmentum: A brain region that sends dopamine-releasing axons to the frontal cortex and limbic system, where that dopamine plays a central role in reward and anticipation of reward.

Biology and Human Behavior:
The Neurological Origins of Individuality
2nd Edition
Part II
Professor Robert Sapolsky



THE TEACHING COMPANY ®

Robert Sapolsky, Ph.D.

Professor of Neurology and Neurosurgery, Stanford University

Robert Sapolsky holds the John A. and Cynthia Fry Gunn Professorship of Biological Sciences at Stanford University, where he is also professor of Neurology and Neurosurgery. His laboratory focuses on the mechanisms by which stress and stress hormones can damage the brain and on the development of gene therapy strategies to save neurons from neurological insults. In addition, Professor Sapolsky has spent his summers since the late 1970s studying a population of wild baboons in East Africa, examining what social rank, personality, and patterns of sociality have to do with vulnerability to stress-related diseases.

Professor Sapolsky writes regularly for nonscientists in such publications as *Scientific American*, *Discover*, *Natural History*, and *The New Yorker*. He is also the author of five books, including four nontechnical publications for the general public: *Why Zebras Don't Get Ulcers: A Guide to Stress, Stress-Related Diseases and Coping*, 3rd edition (2004, Henry Holt); *The Trouble with Testosterone and Other Essays on the Biology of the Human Predicament* (Scribner, 1997); *A Primate's Memoir* (Scribner, 2001); and *Monkeyluv and Other Essays on Our Lives as Animals* (Scribner, 2005).

Table of Contents
Biology and Human Behavior:
The Neurological Origins of Individuality
2nd Edition
Part II

Professor Biography	i
Course Scope	1
	Module V: Molecular Biology, Genetics, and the Neurobiology of Behavior
Lecture Thirteen	What Do Genes Do? Microevolution of Genes 4
Lecture Fourteen	What Do Genes Do? Macroevolution of Genes 8
Lecture Fifteen	Behavior Genetics..... 16
Lecture Sixteen	Behavior Genetics and Prenatal Environment 20
	Module VI: The Ethological Context of Brain and Behavior
Lecture Seventeen	An Introduction to Ethology..... 25
Lecture Eighteen	Neuroethology 27
	Module VII: Integrating Approaches in Studying the Behavioral Neurobiology of Aggression
Lecture Nineteen	The Neurobiology of Aggression I..... 30
Lecture Twenty	The Neurobiology of Aggression II..... 34
Lecture Twenty-One	Hormones and Aggression..... 39
Lecture Twenty-Two	Early Experience and Aggression..... 43
Lecture Twenty-Three	Evolution, Aggression, and Cooperation..... 48
Lecture Twenty-Four	A Summary..... 50
Glossary	Part I
Biographical Notes	52
Bibliography	54

Biology and Human Behavior: The Neurological Origins of Individuality 2nd Edition

Scope:

From time immemorial, the more philosophical among us have pondered: “What is the essence of who I am? What is it that has made me who I am?” Behavioral biology is the science of trying to figure this out, with the guiding assumption that an understanding of who and why we are cannot be achieved without considering our biology.

Now, a human asking these sorts of questions is more complicated, for a myriad of reasons, than a wildebeest asking, “Why is it in my essence to ovulate during one short period of time each year?” or a migratory bird wondering, “Why is it that each year I wish to fly from Tierra del Fuego to Alaska?” Tackling the biology of behavior is particularly daunting when considering humans and their social behaviors.

These challenges are even more extreme when considering an aspect of our behavior that is often the most interesting and important to study: What is the behavioral biology of our *abnormal* human behaviors? Because of the intrinsic intellectual challenge of a subject such as this, and because of its implication, when we ask a question about the biology of abnormal human behavior, we are often, de facto, asking: Whose *fault* is it that this has occurred; who should be held *accountable*? Multiple murderer: damaged frontal cortex or tainted soul? Spouse unable to get out of bed or go to work: victim of the neurochemistry of depression or self-indulgent slacker? Child failing at school: learning disabled or lazy?

This course is an introduction to the biology of human behavior, often of abnormal human behavior, with an emphasis on the brain. The purpose of the course is twofold: first, to teach the contemporary science of how our brains regulate our thoughts, emotions, and feelings—how our brains make us the individuals that we are—and second, to teach how our brains are regulated—sculpted by evolution, constrained or freed by genes, shaped by early experience, modulated by hormones. In this framework, the view is not of the brain as the be-all and end-all of what makes us individuals but, rather, the brain as the final common pathway, the conduit by which our individuality is shaped by biology that started anywhere from seconds to millions of years ago.

After an introductory lecture presenting this framework, a quarter of the course (Modules I and II) will be devoted to the functions of the nervous system. These lectures are updated versions of those in the first edition of this Teaching Company course and will start at the level of how a single neuron functions, building upward until we examine how millions of neurons in a particular region of the brain operate. The focus will be on the regions of the brain most pertinent to emotion and behavior, rather than, say, to regulation of kidney function.

The middle portion of the course (Modules III, IV, and V) will explore how the brain and behavior are regulated. First, we will cover how the brain regulates hormones and how hormones influence brain function and behavior. Then, we will examine how both the brain and behavior evolved, covering contemporary thinking about how natural selection has sculpted and optimized behavior and how that optimization is mediated by brain function. We will then focus on a bridge between evolution and the brain, namely, what genes at the molecular level have to do with brain function and how those genes have evolved.

Hormones, evolution, genes, and behavior, however, do not work in vacuo but, instead, are extremely sensitive to environment. The next section of the course (Module VI) examines *ethology*, which is the study of the behavior of animals in their natural habitats (rather than, for example, in a laboratory cage).

With these various approaches in hand, the final quarter of the course (Module VII) will examine how each approach helps explain an actual set of behaviors. Among a number of possible topics, we will focus on aggression, both because of the extensive information available and the importance of the subject.

The facts of this subject are not intrinsically difficult, even for the nonscientist. The implications, however, should seem far from simple. Yet this is a subject that each of us must master, because all of us are, de facto, behavioral biologists. We serve on juries, deciding whom to incarcerate, whom to put to death. We vote for elected officials who have stances regarding gun control and whether violence is inevitable, who determine whether certain types of love between consenting adults should be consecrated by the government imprimatur of marriage, who help decide whether a certain social problem can be fixed by government expenditures or is biologically irrevocable. And many

of us will have to be behavioral biologists when confronting loved ones whose behaviors have changed them to an unrecognizable extent and deciding whether it is “them” or “their disease.”

The final lecture of this course will consider issues such as these: What are the societal and philosophical consequences of knowledge about the biology of our behaviors, the biology of what makes us the individuals that we are?

Module V

Molecular Biology, Genetics, and the Neurobiology of Behavior

Module Scope:

Evolution is about changing frequencies of genes over time, and the first two lectures of this module focus on what genes actually are and what they do. Key points will be how genes evolve and what genes have to do with the brain and behavior. The latter two lectures will focus on what initially seems to be a simple question: How can you tell when a behavior has a genetic component? As will be seen, this question is vastly difficult to answer. The main intellectual thrust of this section will be to teach how pointless the nature/nurture debate is when considering genes and the brain.

Lecture Thirteen

What Do Genes Do? Microevolution of Genes

Scope: This lecture examines the molecular biology of what a gene actually is and does. The lecture reviews two topics: first, what genes do, particularly with respect to behavior, and second, the false notion of genes as the autonomous instructors, commanding the function of the cell, organ, and body. Instead, the lecture will introduce how the function of genes, particularly in the brain, is heavily controlled by environment.

Outline

- I. The basic theme of the last three lectures has been understanding how this or that behavior has “evolved.”
 - A. “Evolved” really implies changes in genes over time.
 - B. And what do genes have to do with behavior?
- II. In studying what genes actually do, we must begin with the function and structure of proteins. (Figure 13a)
 - A. Things we have encountered so far in the course that are made of protein include receptors for hormones and neurotransmitters, many neurotransmitters and hormones themselves, and the enzymes that make them and break them down.
 - B. Proteins are made of a 20-letter alphabet of amino acids.
 - C. Each of the 20 different amino acids has a different shape.
 - D. When you string the amino acids together to form a protein, each protein has its own unique shape.
 - E. The shape of a protein determines its function. Just think of the protein key (of a hormone, for example) fitting into a protein lock (its receptor).
 - F. Genes specify the amino acid sequence that determines the function of a protein.
- III. In the next step in studying what genes actually do, we must look at how the synthesis of proteins is directed. (Figure 13b)
 - A. DNA is composed of long strings of a four-letter alphabet of molecules.
 - B. A combination of three of those DNA letters in a row codes for one of the amino acids.
 - C. A string of those three-letter DNA codes in a row instructs the string of amino acids that are stuck together to form a particular protein.
 - D. There are unique three-letter DNA codes that indicate the beginning and end of the DNA stretch that codes for a specific protein.
 - E. The stretch of DNA that makes up the complete code for a single type of protein is called a *gene*. The human *genome* (the totality of DNA codes) contains about 30,000 genes.
 - F. This 30,000-gene-long book of DNA can get cumbersome; for this reason, it is broken into separate volumes, called *chromosomes*.
- IV. Finally, in studying what genes actually do, we come to the intervening step of RNA.
 - A. A single copy of each book of DNA exists in each cell, stored in the nucleus.
 - B. However, protein synthesis occurs in every far-flung corner of a cell.
 - C. For convenience, when a gene is activated to direct the construction of its cognate protein, an RNA “photocopy” of that gene is made and shipped to the part of the cell where that protein is needed.
- V. How do genes evolve?
 - A. When a cell divides, a copy of all the DNA is made for the new cell.
 - B. A mutation is an error in that copying, and when such an error occurs in an egg or sperm, it can be inherited.

1. Deletion and insertion mutations are typically disasters, producing a nonfunctional protein.
 2. Point mutations can produce subtle changes in protein shape and, thus, protein function.
- C. This is the grist of evolution.
1. A receptor for some neurotransmitter becomes a little bit more or less responsive to the messenger than it used to be.
 2. An enzyme that synthesizes some hormone is a little more or less active than it used to be.
 3. And as we saw back in Lecture Three, one's level of anxiety can be influenced by how well one's benzodiazepine receptors work.
- D. From there, we can go back to Darwin and ask if a genetic change makes the organism more or less likely to reproduce.

Further Reading:

For a classic overview of how genes work by the codiscoverer of the structure of DNA:

J. Watson, et al., *Molecular Biology of the Gene*, 5th ed.

For an excellent introduction to what genes might have to do with behavior:

R. Plomin, *Behavioral Genetics*, 3rd ed.

Questions to Consider:

1. What do proteins have to do with behavior?
2. How might microevolutionary changes over the course of evolution pertain to behavior?

Figure 13a

DNA to Receptor

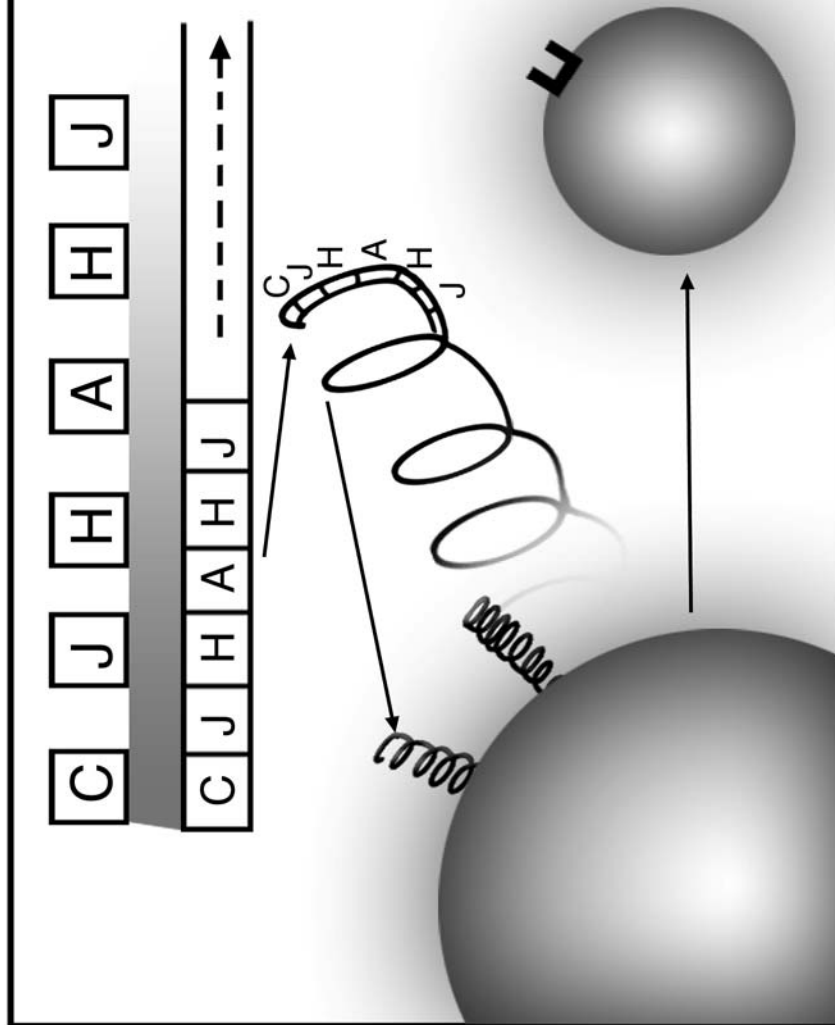
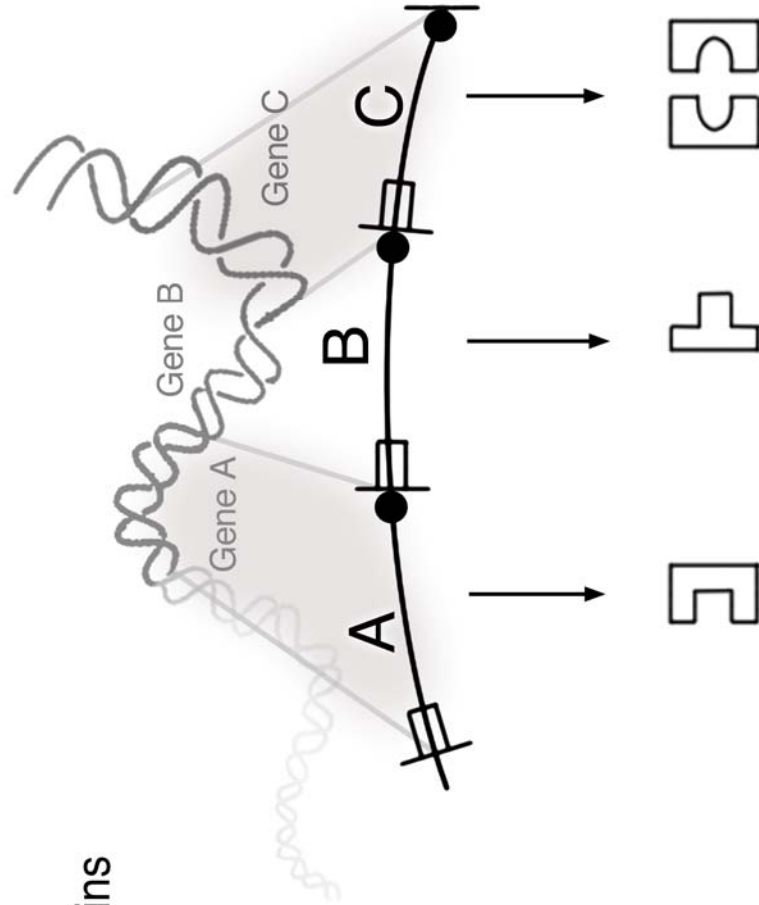

Figure 13b

Coding for Proteins



Lecture Fourteen

What Do Genes Do? Macroevolution of Genes

Scope: *Evolution* can be formally defined as changes in the function and distribution of genes in populations over time. But what exactly evolves in a gene on the molecular level? This lecture reviews what mutations are on that level and how they can affect behavior. The classical model of mutations is presented, and more recent studies suggest ways in which dramatic genetic changes, many relevant to behavior, can occur rapidly.

Outline

- I. What do we know at this point?
 - A. Continuous stretches of genes contain coding for different proteins.
 - B. Mutations within genes change the function of the protein they produce.
- II. Genes, however, are not continuous in DNA. (Figures 14a, 14b, and 14c)
 - A. *Introns* are intervening sequences of DNA that break up genes into parts called *exons*.
 - B. We can temporarily consider the intervening DNA, which accounts for 95 percent of all DNA, to be “junk.”
 - C. A whole protein is made out of this fragmented DNA code with splicing enzymes, that is, enzymes that cut out the intervening sequences and pull the protein together.
- III. Now we can explore the potential for macroevolutionary change. (Figure 14d)
 - A. Previously, we saw evolution producing changes in function of preexisting genes. Now, we come to evolution producing entirely new genes.
 - B. If there is a mutation in a gene coding for a splicing enzyme, the result may be the generation of two different proteins, two different messengers from the same precursor.
 - C. Another route for macroevolutionary change can be found in *transposable genetic elements*.
 1. The heresy and ultimate triumph of Barbara McClintock’s theory of “jumping genes” is an epic story.
 2. What sorts of species have lots of transposable genetic events?
 - a. Species that can’t run away from stressors, such as plants.
 - b. Parasites that are trying to evade an immune system.
 - c. Immune systems that are trying to get those parasites.
 3. The consequence of a transposable genetic event in an egg or sperm is the potential for the inheritance of an entirely new gene.
- IV. One last major complexity entails promoters and transcription factors that are the instructions for when genes are activated, when gene transcription should begin, and when the gene should start making an RNA copy and splicing. (Figure 14e)
 - A. Now we need to revisit that noncoding (*intronic*) DNA that we temporarily called “junk.”
 - B. Instead of being junk, that noncoding DNA often decides when a gene is turned on or off.
 - C. Regulation of gene transcription requires promoters and transcription factors.
 1. *Promoters* are the switches that turn gene transcription on and off.
 2. *Transcription factors* are proteins that throw those switches.
- V. What regulates transcription factors? (Figure 14f)
 - A. The world within the cell but outside the nucleus can determine when a gene is turned on.
 - B. The world within the organism but outside the cell can activate a gene.
 - C. The outside environment can trigger internal reactions that turn a gene on.

- D. The introduction of “if-then” clauses adds another dimension into gene regulation. Hypothetically, if you start with an established if-then clause (If it is the dry season, then retain water.) and add one mutational event, you have a new genetic if-then clause (If it is the dry season, *then ovulate*).
- VI. *Punctuated equilibrium* is a theory that evolution actually involves long periods of stasis interspersed with periods of relatively rapid and dramatic changes.
- VII. We must place genes in the context of environment.
- A. Genes no more give commands than do telephone books.
 - B. You cannot understand genes without understanding their regulation by the environment, which makes “gene versus environment” or “nature versus nurture” debates meaningless.
- VIII. We also have to consider macroevolutionary changes in gene regulation.
- A. What if you have a mutation in a promoter sequence?
 - B. What if you have a transposable event in a promoter sequence?
 - C. Evolution works faster on introns than on exons.
 - D. Therefore, evolution is more about changes in the regulation of genes by the environment than about changes in genes themselves and the proteins they code for.
- IX. A final point is that there are more genes whose expression is unique to the brain than to any other part of the body.

Further Reading:

For two excellent introductions to the subject:

D. Moore, *The Dependent Gene: The Fallacy of Nature vs. Nurture*.

M. Ridley, *Nature via Nurture: Genes, Experience, and What Makes Us Human*.

For a massive overview of the idea of punctuated equilibrium:

S. Gould, *The Structure of Evolutionary Theory*.

Questions to Consider:

1. How is the structure of genes relevant to the way that evolution works?
2. How might macroevolutionary change be relevant to understanding the evolution of behavior?

Figure 14a

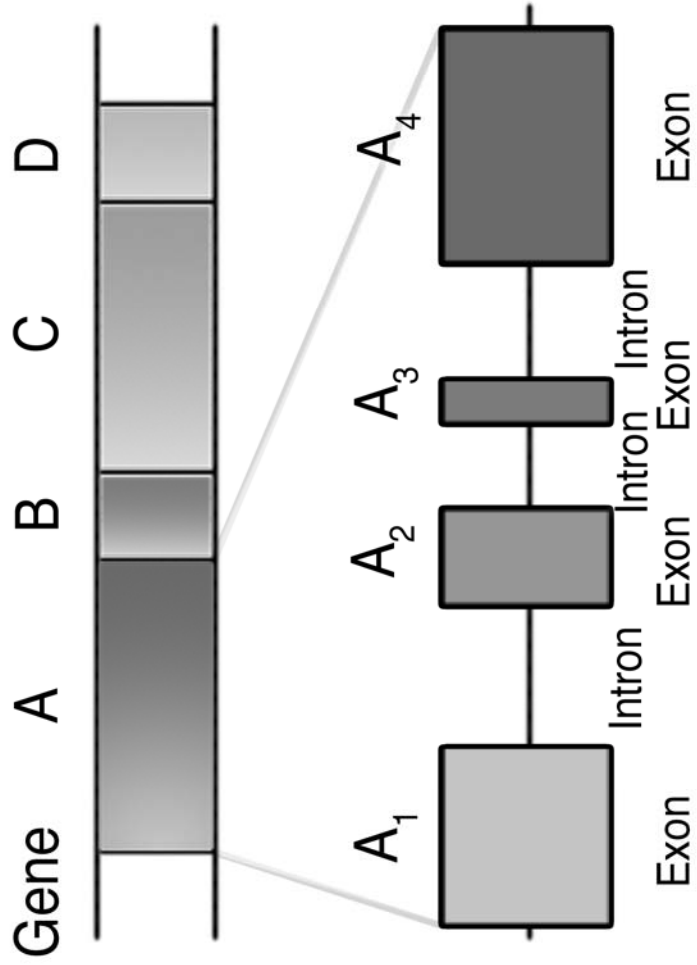

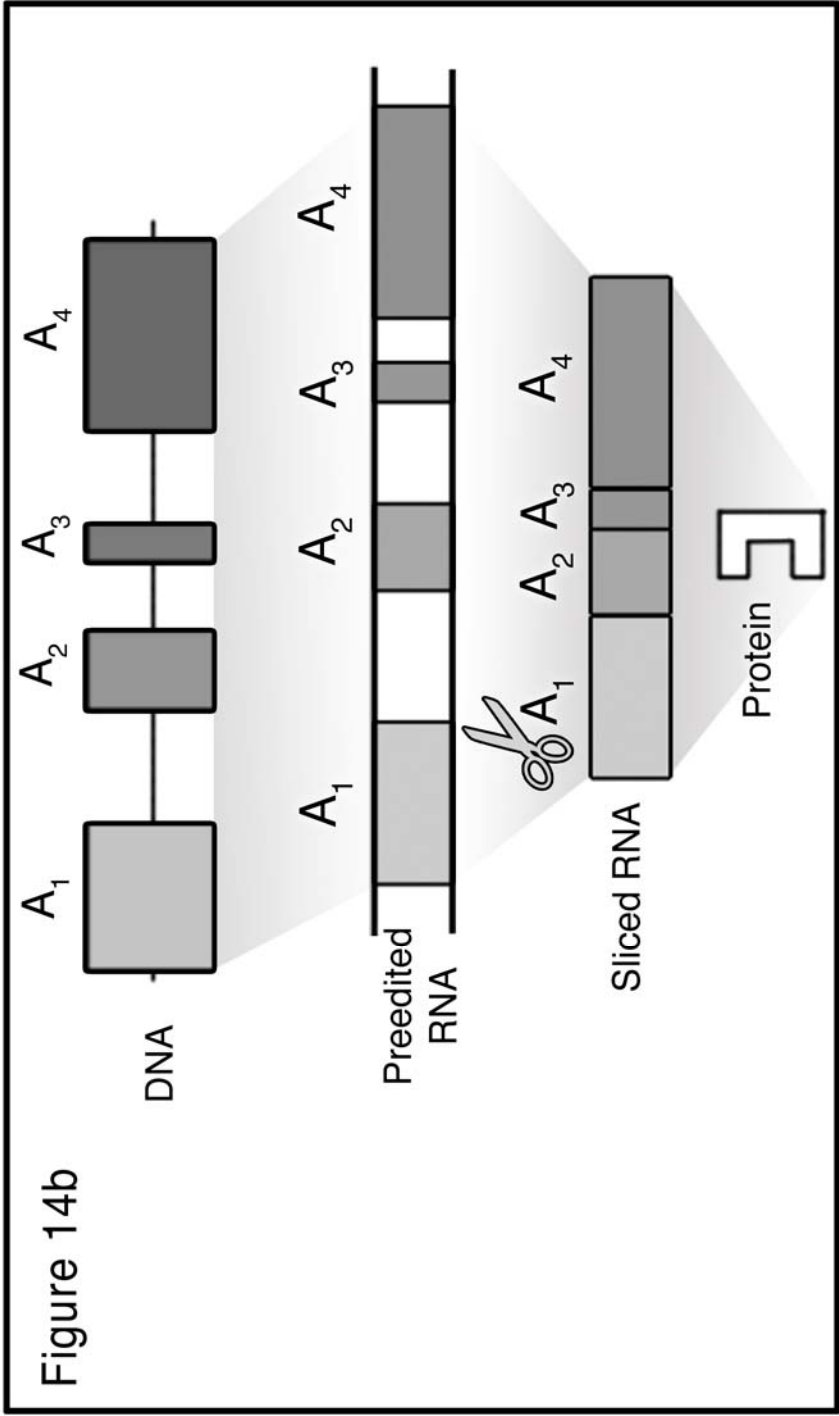
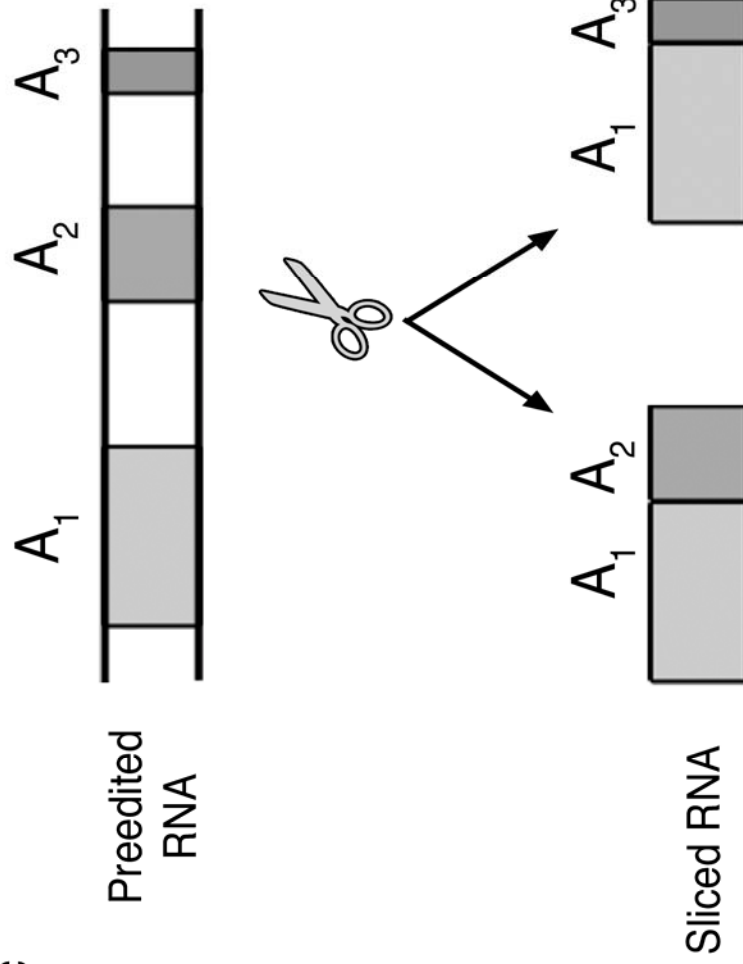
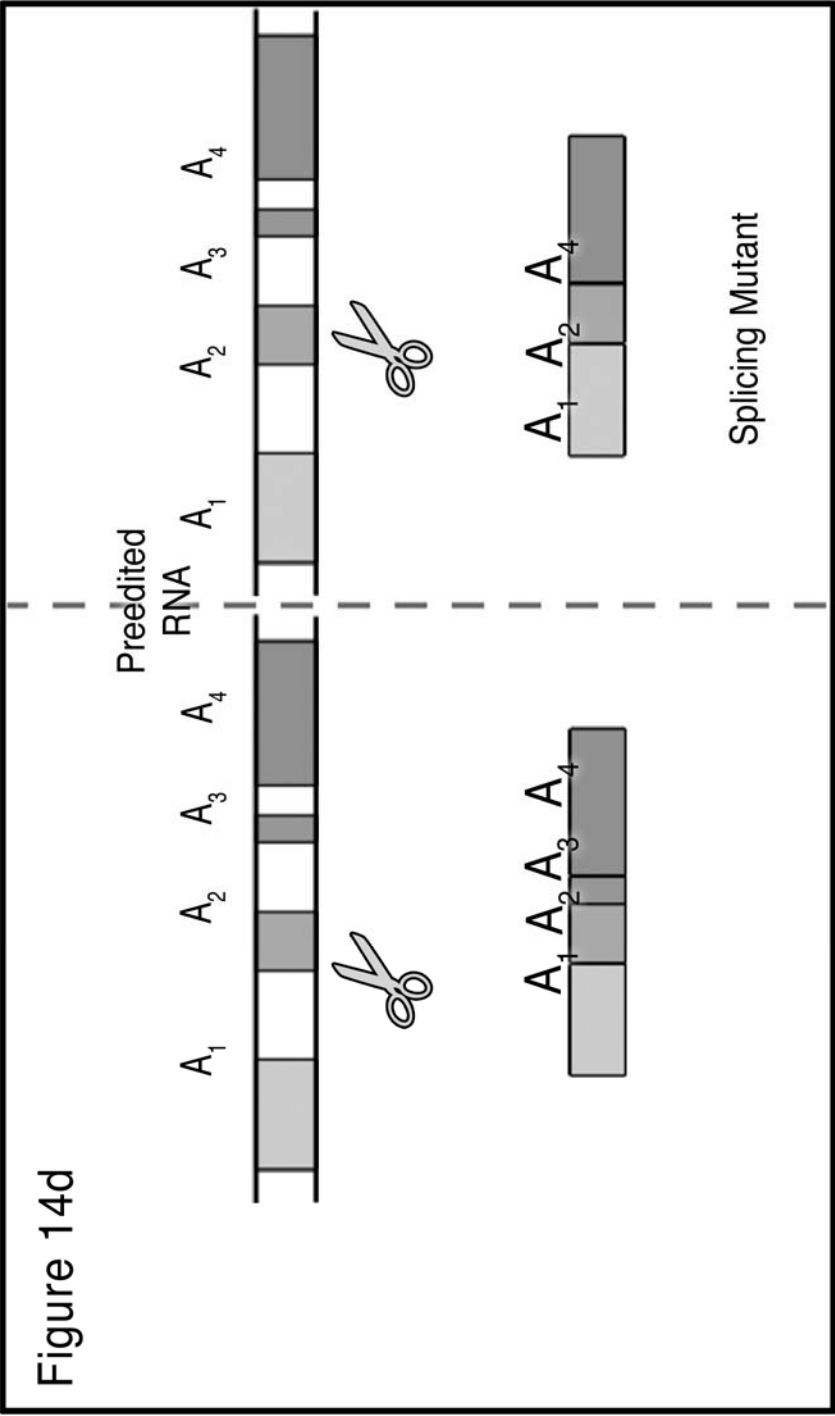

Figure 14b

Figure 14c





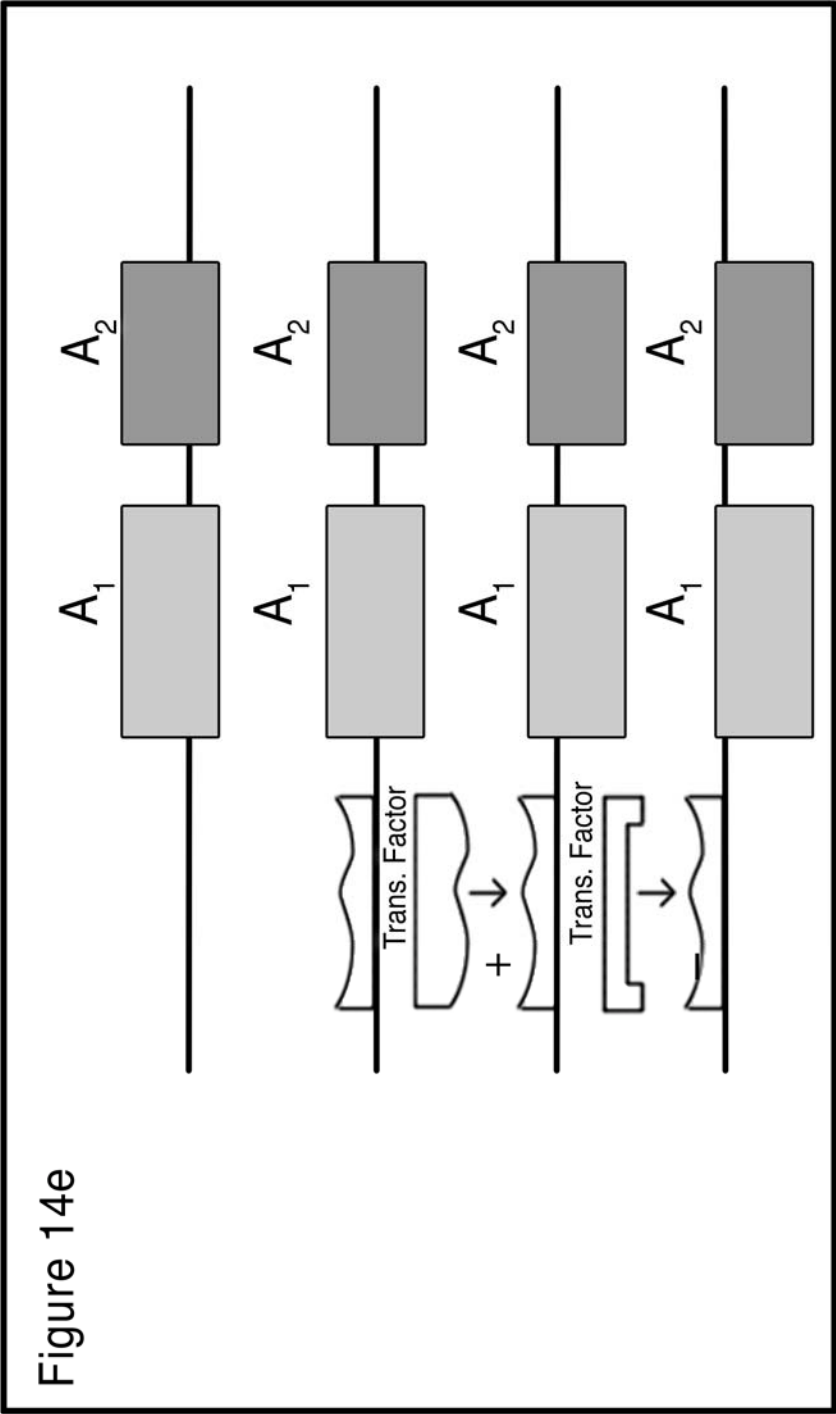
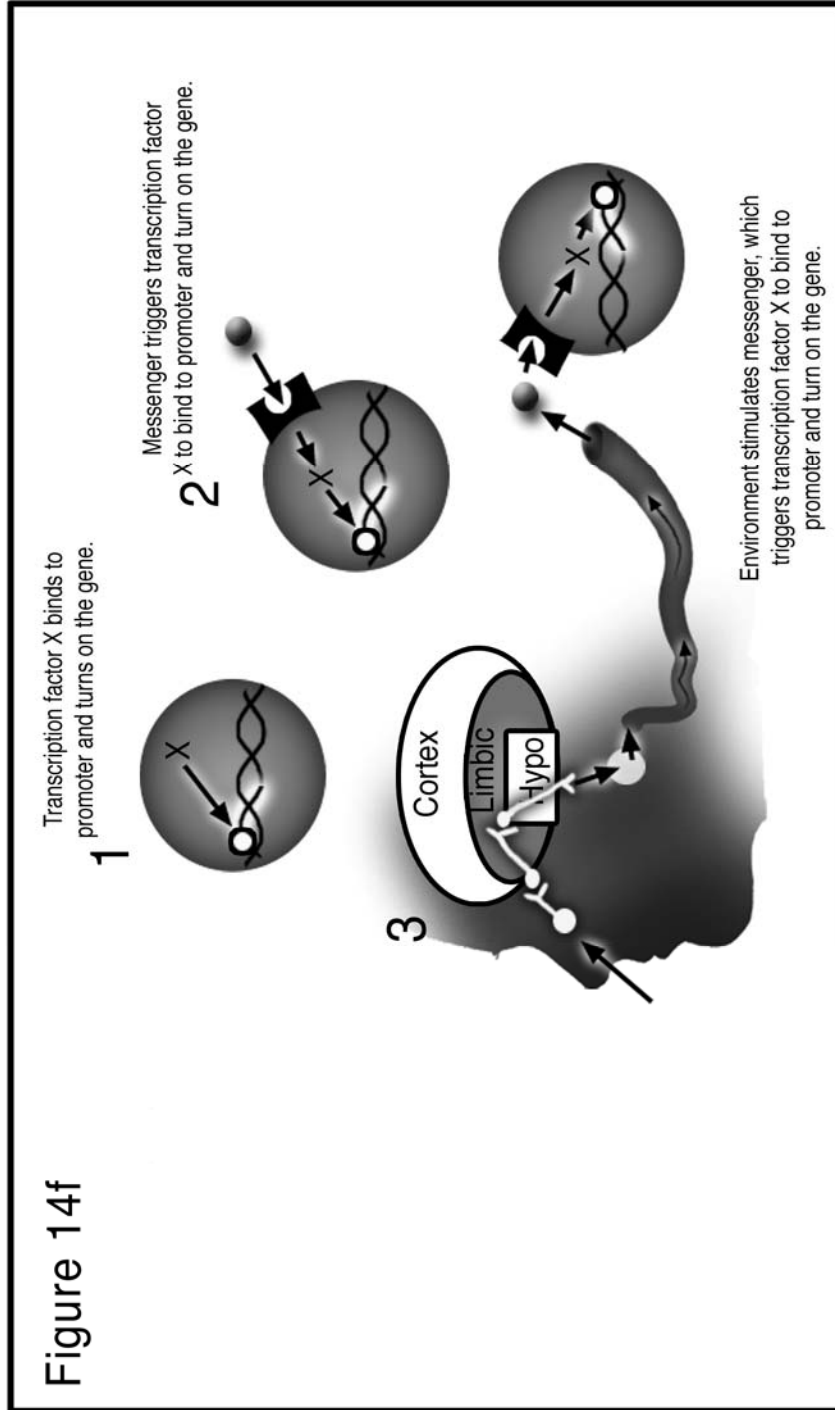

Figure 14f



Lecture Fifteen

Behavior Genetics

Scope: This lecture introduces the field of behavior genetics, which has sought to determine the extent to which genes explain such qualities as intelligence, aggression, or introversion/extroversion. The standard techniques of the field are introduced: studies of extended families, studies of identical versus fraternal twins, and adoption studies. A critical and underappreciated concept is also introduced—how much do genes influence a behavior versus how much do they influence the *variability* in a behavior?

Outline

- I. First, let's look at behavior genetics as a discipline.
 - A. In Lectures Ten through Twelve, we saw how an evolutionary biologist infers that something is “genetic.”
 - B. In Lectures Thirteen and Fourteen, we learned how a molecular biologist infers that something is “genetic.”
 - C. In this lecture, we will see that a behavior geneticist infers that something is “genetic” by comparing patterns of shared behaviors and shared genes in a population.
- II. For starters, let's look at everything we have learned so far and determine what it does *not* mean to say that a behavior is “genetic”: Genes are not deterministic; they do not inevitably cause some behavior; and they are not impervious to environment. Instead, genes can only support propensities or tendencies to a particular behavior.
- III. An initial simplistic approach is to say that genes run in families; thus, if a behavior runs in a family, it must be genetic. The flaw in that approach is that environment runs in families as well.
- IV. A slightly less simplistic approach theorizes that close relatives share more genes in common than distant relatives; thus, if a behavior is shared more among close than distant relatives, it must be genetic.
 - A. One example of this approach, which we will examine more deeply later in this lecture, is the covariance of relatedness and the incidence of depression.
 - B. The flaw here, however, is that environment is shared more among close relatives than distant ones.
- V. One sophisticated contemporary approach states: “If two individuals raised in an identical environment but with different genes differ in a behavior, then that behavioral difference can't be due to environment.” (Figure 15a)
 - A. This brings us to the gold mine of comparing identical and fraternal twins.
 1. The general approach is to study identical twins raised in the same household and fraternal twins raised in the same household. If the study of fraternal twins reveals differences, the assumption is that those differences must reflect genetics, given the shared environment.
 2. An example of findings with this approach is the study of the heritability of obsessive-compulsive disorder.
 3. One problem with the twin approach is that environment is not identical, particularly for fraternal twins and especially if fraternal twins are of different genders.
 - B. A study of the influence of gender and math skills underscores the potential importance of environmental factors.
 1. A small difference in average performance and a big difference in the extremes of math achievement between boys and girls were discovered.
 2. Differences were demonstrable among early adolescents, at a level when all students took the same classes. Hence, we have the claim by the authors of the study that the educational environment was identical.
 3. But were the students' educational environments identical? Not when boys are praised by teachers in that environment more than girls and girls underestimate their math abilities even when those abilities show the same level of performance as that of boys.

- C. Another study looked at the differences in activity in newborns as a function of gender and ethnicity, but environmental differences can be shown to exist even within minutes of birth.
- VI. Another contemporary approach states, “If two individuals share many genes but live in different environments and if they share a behavior, then that behavior must be genetic.”
- A. This leads to the classic adoption approach, an example of which is the Kety studies and the genetic contribution to schizophrenia. (Figure 15b)
 - B. There are problems with this approach as well.
 - 1. Are environments really different? No, not with nonrandom placement by adoption agencies trying to place children with parents of the same race and ethnicity and other factors.
 - 2. Another flaw with this approach is the reality that an adopted child shared a great deal with its mother in the fetal environment.
- VII. Another contemporary approach states, “If two individuals with identical genes but raised in different environments share a behavior, then that behavior must be genetic.”
- A. Identical twins separated at birth are the holy grail of behavior genetics. The sorts of findings involving such individuals include the extent of heritability for IQ, introversion/extroversion, and degree of aggression.
 - B. There are some drawbacks with this approach as well because environment and genetics are so closely intertwined.

Further Reading:

For an excellent book by a leader in the field:

R. Plomin, *Behavioral Genetics*, 3rd ed.

For a very strong critique of behavioral genetics, written by an eminent geneticist:

R. Lewontin, *It Ain't Necessarily So: The Dream of the Human Genome and Other Illusions*.

Questions to Consider:

1. What are some of the most common approaches used by behavior geneticists to identify a genetic influence on a behavior?
2. What are some of the confounds of these approaches?

Figure 15a

Shared Environment,
Different Genetic Makeup

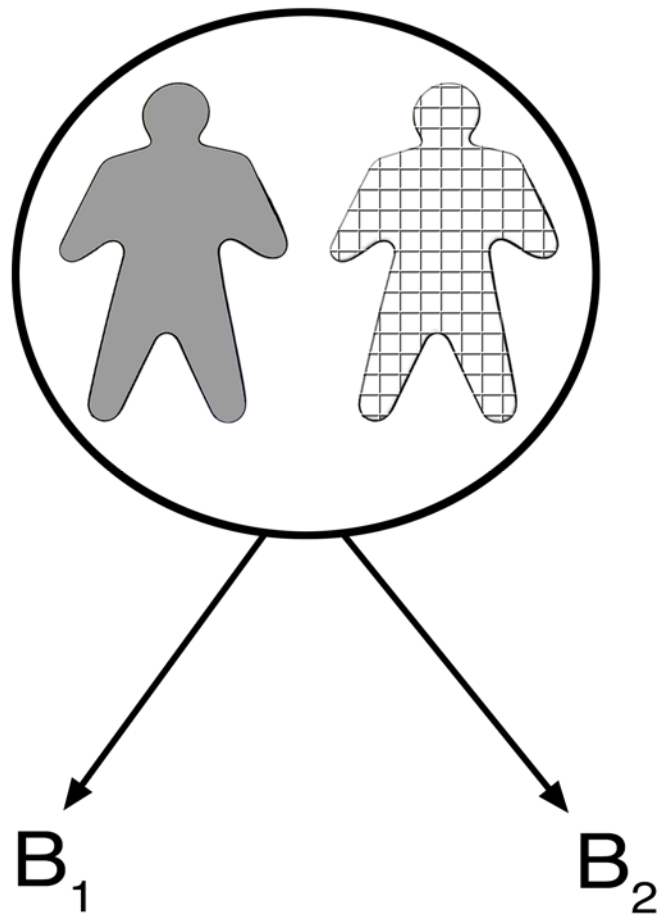

Figure 15b

Biological Parent

Schizophrenic Not

16	3
9	1

Schizophrenic Not

Adoptive
Parent

Lecture Sixteen

Behavior Genetics and Prenatal Environment

Scope: The basic premise of behavior genetics is that research controls for environment and, thus, reveals the effects of genes. This lecture shows that this is virtually impossible to do because genes and environment constantly interact, particularly in the realm of behavior. Moreover, environmental effects occur in all sorts of unexpected realms. In this lecture, we review a striking set of examples concerning the extent to which the environment of a fetus can influence its brain and behavior for the rest of its life.

Outline

- I. Another contemporary approach states, “If a behavior is demonstrable before there are any relevant environmental influences, then it must be genetic.”
 - A. Some animal examples support that approach.
 - 1. Rhesus monkeys raised in isolation express subordinate gestures when confronted with a threatening rhesus face.
 - 2. Rodents raised in a lab have an aversion to cat smell.
 - B. Some human examples support that approach as well.
 - 1. Babies who are blind smile at the same age socially as infants who can see.
 - 2. Likewise, congenitally deaf babies begin babbling at the same time as hearing babies.
- II. The major problem with this approach is that environment does not begin at birth.
 - A. A fetus shares an intimate circulatory environment with its mother and her environment.
 - B. What outside influences reach a fetus?
 - 1. Hormones: Whatever hormonal events are going on in the mother’s body can influence the offspring.
 - 2. Nutrients: Glucose and other nutrients are delivered to the baby through the mother’s bloodstream.
 - 3. Sounds: After developing a working auditory system, a fetus can hear sounds.
- III. The endocrine environment for a fetus is affected in many ways.
 - A. Hormones can reach the fetal circulation transplacentally. Mechanisms at the placental boundary prevent some hormones from reaching the fetus, but many get through.
 - B. Because a rodent fetus is getting bathed in the hormones of its closest sibling, hormonal events may depend on whether the sibling next to it in the uterus is the same sex.
 - 1. If female rodents are exposed to a lot of male sex hormones during development, they will start ovulating at a later age than the average female, and they will become infertile at an earlier age.
 - 2. Likewise, they will show more characteristics of rough-and-tumble play as rat pups.
 - C. The amount of stress hormones a mother secretes during pregnancy can affect a fetus’s development as well.
 - 1. In rodents, long-lasting effects can be seen in brain development, cognition, and emotion.
 - 2. Stress during pregnancy can also lead to the “nongenetic” inheritance of traits across generations.
 - 3. Prenatal maternal stress during the third trimester has been found to lead to smaller head circumference in human babies.
- IV. The nutritional environment for a fetus is equally important.
 - A. Food availability in the outside world gets translated into nutrient levels in the fetal circulation.
 - B. An astonishing example is metabolic programming and the Dutch Hunger Winter of 1944–1945.
 - 1. Prenatal malnutrition led to development of the *thrifty metabolism* in fetuses.

2. Later in life, individuals who developed such thrifty metabolisms were found to develop long-term disease consequences, such as increased risk of hypertension, obesity, adult-onset diabetes, and metabolic syndrome.
 3. The multigenerational consequences of such deprivation have also been identified, including subtle malnutrition of fetuses born of women who developed the thrifty metabolism.
- V. A third area of interest is the auditory environment for a fetus.
- A. The body is a great resonating chamber; thus, when a mother reads to her unborn baby, her voice resonates internally, and the fetus senses the rhythm and meter of the sound of books being read.
 - B. Studies of prenatal learning show that babies recognize the difference between new books and books read to them by their mothers during the last trimester of their development. Studies of fathers' or other outsiders' readings do not show the same results.
- VI. The implications of prenatal environmental effects are extraordinary. Traits can be inherited multigenerationally and have *nothing* to do with genetics.
- VII. Some final critical points still must be covered: What does it mean when a behavior in a plant or animal is found to be, say, 60 percent "heritable"? (Figures 16a and 16b)
- A. Everyone thinks this term means that some gene(s) is 60 percent responsible for controlling some behavior.
 - B. What *heritability* actually means is the degree to which genes account for the *variance* of some trait, not the average amounts of some trait.
 - C. You cannot determine what percentage of a behavior is under the control of genetics.
 1. Gene-environment interactions must be considered, not just genes or environment.
 2. An amazing example: A certain type of serotonin transporter gene increases your risk of clinical depression *if and only if* you are raised in a stressful environment.

Further Reading:

For an excellent book by a leader in the field:

R. Plomin, *Behavioral Genetics*, 3rd ed.

For a very strong critique of behavioral genetics, written by an eminent geneticist:

R. Lewontin, *It Ain't Necessarily So: The Dream of the Human Genome and Other Illusions*.

Questions to Consider:

1. How does one refute the view that environmental influences commence at birth?
2. How are fetal environmental effects relevant to brain function?

Figure 16a

Gene Coding
Example 1

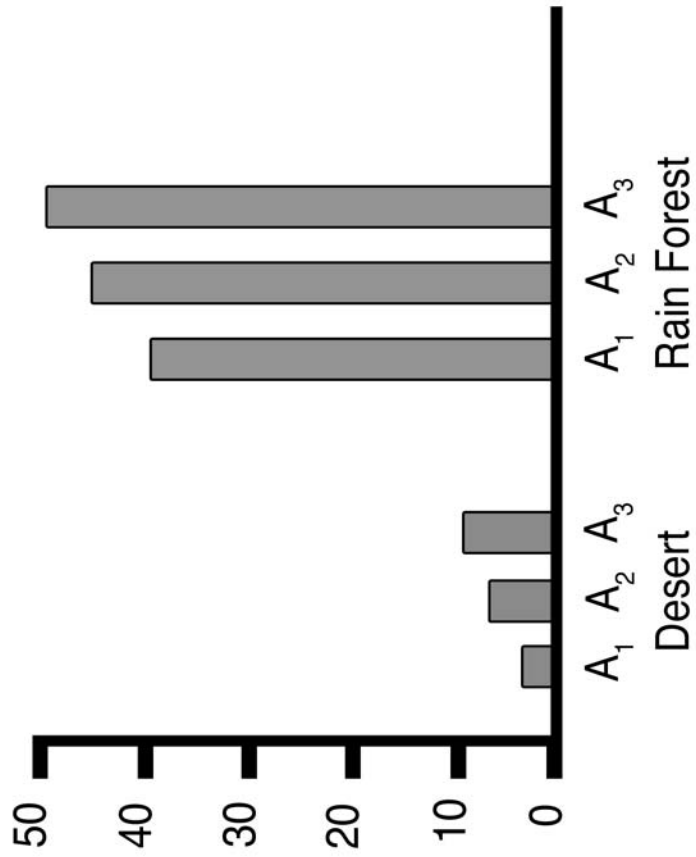

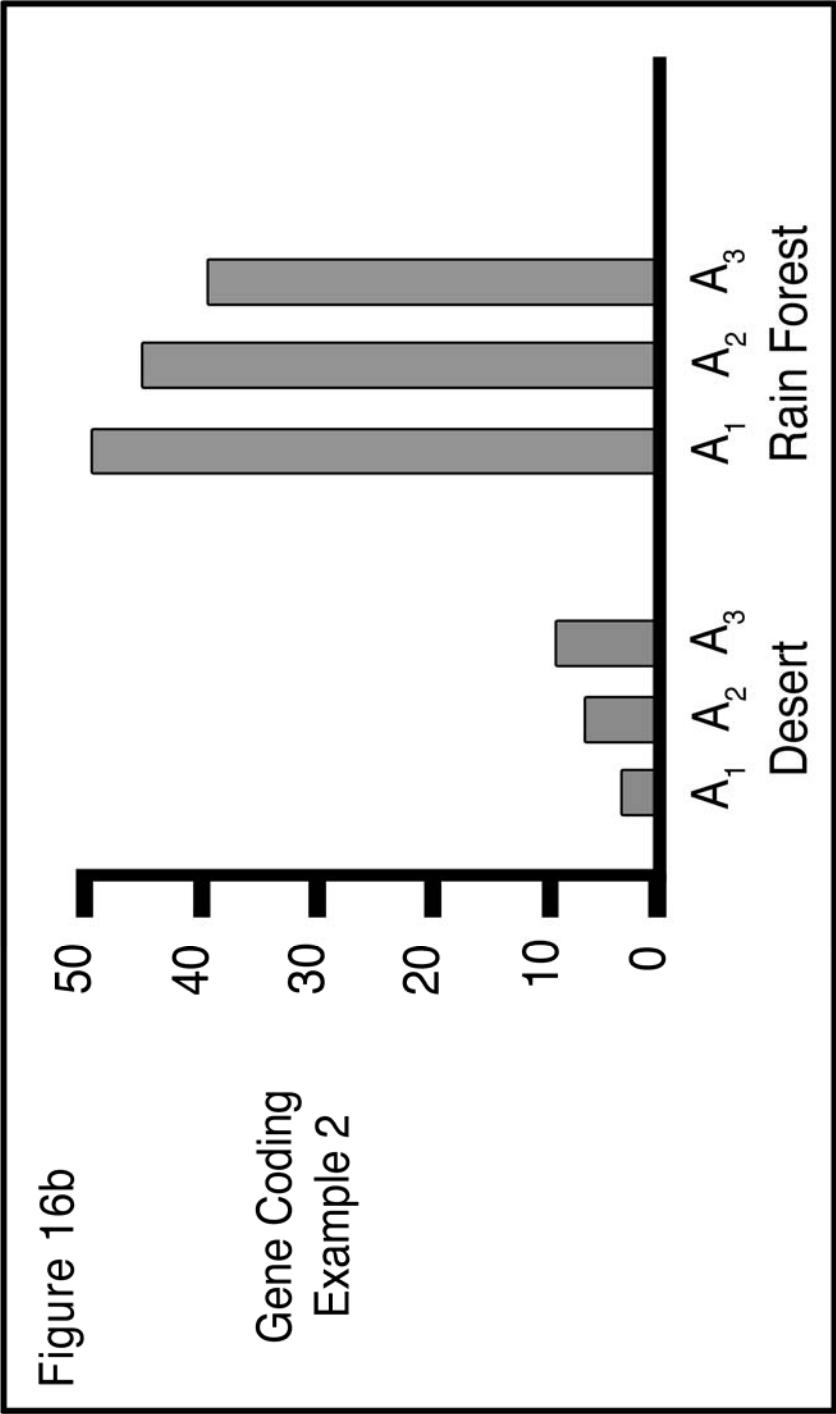

Module VI

The Ethological Context of Brain and Behavior

Module Scope:

The lectures in this module focus on how insights about the human brain and behavior can be derived from the study of animals in their natural habitat. This approach, termed *ethology*, developed as a counter to behaviorist psychology, which basically had the view that a rat equals a pigeon equals a monkey equals a human and that rules of behavior are universal, transcending particular species. Ethology counters this view, and the purpose of these lectures will be to examine the neurobiology of human behavior in the context of our being only one of many social species.

Lecture Seventeen

An Introduction to Ethology

Scope: A huge percentage of what we know about the brain bases of behavior comes from the study of laboratory animals. The field of ethology was founded on the utterly correct idea that an animal in captivity rarely behaves normally. This lecture gives an overview of the ethological approach to studying behavior, including that of humans.

Outline

- I. The rationale for studying ethology is that if you really want to understand an animal's behavior, you have to study it in the context of that animal's natural setting.
 - A. Back to the limbic system: How do you understand how a brain region influences a particular behavior if you do not understand the behavior?
 - B. And how normal is an animal's behavior in a cage?
 - C. Thus developed the field of ethology: the study of animals in their natural setting.
- II. The historical context of ethology is interesting because it developed as a counterbalance to behaviorism.
 - A. In the mid-20th century, psychology in America was dominated by behaviorism.
 1. B. F. Skinner, the most famous adherent to behaviorism, believed, "Pigeon, rat, monkey, boy. It doesn't matter."
 2. He believed that all behavior could be shaped by reward and punishment.
 - B. Meanwhile, out in the marshes and woods of Europe, ethology was being founded.
 1. One of the founders, Niko Tinbergen, summed up his philosophy in this sentence: "An experiment should be like a conversation with an animal...but in the animal's own language."
 2. Tinbergen, Karl von Frisch, and Konrad Lorenz won a Nobel Prize for founding ethology.
 3. They believed that the behavior of any given species is a unique set of solutions to a unique history of environmental challenges.
 - C. We need to look at the approach of ethology.
 1. The first question Tinbergen, von Frisch, and Lorenz asked was always: "What's the behavior?" They looked for the *fixed action patterns (FAPs)* and strived to objectively describe the behavior.
 2. The second question they asked was: "What is the behavior good for?" They studied the *adaptive value* of the behavior.
 3. The third question they asked was: "What triggers this behavior? What were the *releasing stimuli* for the FAP?"
 4. Finally, they asked: "How is the behavior mediated physiologically?" What were the *innate releasing mechanisms* that led to the behavior?
 5. They also looked at what role learning plays in behavior, including imprinting and prepared learning, which will be covered in Lecture Eighteen.
- III. FAPs merit more detailed study.
 - A. Is talking about FAPs just a fancy way of talking about "instincts"?
 1. Ethologists tried to tame the notions of instincts for aggression or maternal behavior or xenophobia and break them down into FAPs—more manageable packages for narrow, explicit behaviors.
 2. Ethologists observed that FAPs are expressed in the absence of learning and experience but are subsequently shaped by experience.
 - B. We have several examples of FAPs.

1. Baby squirrels know how to crack nuts the first time they see one. They do not need to learn by trial and error or by mimicking an adult squirrel. However, the more they do it, the better and faster they get.
2. As we have seen, isolation-reared vervet monkeys recognize and react appropriately to a threatening vervet monkey face. With more social experience, the isolation-reared monkey learns more appropriate behavior.
 - a. Vervet monkeys also have two different alarm calls, one signaling others to get up a tree because a snake is approaching and one signaling others to get down because a raptor bird is coming.
 - b. The proof that adult vervets understand the principles of ethology comes in discovering that adults ignore these vocalizations when they are emitted by young monkeys because the young are likely to give incorrect signals; they do not react until an adult vervet confirms the alarm call.
3. Human infants smile even in utero, but we learn to smile in appropriate contexts.
4. Perfect pitch in humans has a significant genetic component, but it also requires a musical environment early in life for it to develop.

IV. The adaptive value of FAPs is also worth examining more closely.

- A. The ethologists' view of the adaptive value of FAPs differs from the just-so stories of many evolutionary biologists.
- B. Some examples of adaptive behavior prove the point.
 1. Tinbergen discovered that gulls turn the eggshells of their chicks to show the outer speckled side after the chick has hatched to protect the chicks from predators. This works, because the pure white inner-shell fragments more readily attract the attention of a predator.
 2. Von Frisch studied bee dances, which bees use to communicate to other bees the location of a food source.
 3. Sick lizards give themselves a fever, aiding their immune system.

V. We will look at releasing stimuli and innate releasing mechanisms in our next lecture.

Further Reading:

For a great introduction to ethology:

J. Alcock, *Animal Behavior: An Evolutionary Approach*, 7th ed.

For a nice biography of Tinbergen (truly a giant of a scientist and person):

H. Kruuk, *Niko's Nature: The Life of Niko Tinbergen and His Science of Animal Behaviour*.

Questions to Consider:

1. How does the ethological approach to understanding behavior differ from that of other disciplines?
2. How does a fixed action pattern differ from how people have thought about "instinct" or something being "innate" or "genetic"?

Lecture Eighteen

Neuroethology

Scope: This lecture picks up on Lecture Seventeen in giving an overview of neuroethology, which seeks to understand the neurobiology of behavior from the standpoint of studying behavior in the natural settings of animals. The lecture places particular emphasis on how the functioning of the limbic system varies among different species and how to understand the human limbic system in that context.

Outline

- I. We start with the basic questions of ethology and its intersection with neurobiology.
- II. After studying FAPs and adaptive value, ethologists look at releasing stimuli.
 - A. This intersection of sensory systems and the limbic system explains why scientists used to call the limbic system the “nose brain” (*rhinencephalon*).
 - B. The experimental approach includes substitution, replication, and superstimulation.
 - C. Examples of releasing stimuli reveal that there are all different types of sensory communication and that they differ dramatically from species to species.
 1. A male deer attracts a mate by vocalizing.
 2. An electric fish, in contrast, courts through emitting electric “songs.”
 3. Turkey mating requires visual stimuli.
 4. Olfaction and mating among rodents involves pheromones. Through pheromonal information alone, these animals can tell what the gender of another rodent is, what that individual’s health status is, whether it is stressed or scared, and whether it is ovulating or has testes.
 5. What releasing stimulus makes an infant monkey become attached to its mother? The brilliant, disturbing studies of Harry Harlow showed that, when given a choice between an artificial mother that was made of chicken wire and gave milk and a similar chicken-wire mother who gave no milk but was covered with soft felt, the baby monkeys chose the felt-covered mothers. This experiment marked the defeat of simplistic behaviorism.
 6. Threatening faces and activation of the amygdala in humans serve as another example.
 - a. Is the face of someone of another race a releasing stimulus for amygdala activation? It depends on the setting and context.
 - b. Experiments have shown that if a viewer is forced to think of the person of another race as an individual (through a subtly worded question, for example), the amygdala does not activate when that person’s picture is viewed.
- III. Ethologists also study innate releasing mechanisms.
 - A. This used to be an area where ethologists just speculated.
 - B. The blending of the techniques of ethology and of neurobiology has led to some striking discoveries.
 1. Scientists now understand the neurobiology of seasonal bird song dialects.
 2. The circuitry diagram of the lordosis reflex has been charted with a neuroethological map.
 3. Trauma produces a hyperreactive amygdala, and scientists are close to constructing a circuitry map for posttraumatic stress disorder.
- IV. Learning is an area that ethologists have studied as well.
 - A. To a behaviorist, learning is related to the world of punishment and rewards.
 - B. One depressing example that runs counter to the behaviorist view, while supporting that of ethology, concerns cases of abuse: Why do some of us love individuals who treat us poorly?
 - C. What learning means to an ethologist is different from what learning is to behaviorists.

1. *Traditional learning*: Ethologists have found that traditional learning occurs in unlikely places. For example, they have found that primate maternal competence is not an instinct; it is learned over time.
2. *Imprinting*: In working with ducklings, Lorenz studied *imprinting* and saw how baby ducks learned to identify their mother.
3. *Prepared learning*: Ethologists found that certain behaviors are learned more easily than others.
 - a. Naïve birds exposed to songs from their own species and those of a related species are more likely to learn songs of their own species.
 - b. Monkeys are predisposed to be terrified of snakes.
 - c. The sauce béarnaise syndrome shows that humans who are nauseated associate their sickness with tastes more readily than with sounds.
 - d. Babies can learn the phonemes of any language but are better at recognizing language than nonlanguage sounds.

V. The place of ethology is critically important.

- A. Studying behavior in its natural setting is truly helpful. We cannot understand the brain and how it works without understanding the special evolutionary and ecological settings, the solutions, and the language of behavior that each species has developed.
- B. But what is the natural setting of a human?

Further Reading:

For a great introduction to ethology:

J. Alcock, *Animal Behavior: An Evolutionary Approach*, 7th ed.

For a nice biography of Tinbergen (truly a giant of a scientist and person):

H. Kruuk, *Niko's Nature: The Life of Niko Tinbergen and His Science of Animal Behaviour*.

Questions to Consider:

1. In what ways is the concept of “prepared learning” relevant to understanding human behavior?
2. What does an ethological perspective teach you about the function of the limbic system?

Module VII

Integrating Approaches in Studying the Behavioral Neurobiology of Aggression

Module Scope:

The previous modules have examined how the brain produces individual differences in behavior and how such brain function is regulated. With this interdisciplinary approach in hand, this final module applies this framework to an actual example of behavior. To do so, we will focus on the neurobiology of aggression. This subject has been chosen for two reasons. First, an enormous amount is known about the subject (far more than, say, parental behavior, attachment, or language use), and the subject is particularly amenable to an integration of the various approaches introduced in this course. Second, there are few subjects more important for people to understand—a dire threat to our future is the human capacity for violence.

The structure of these lectures will be to first present an extensive overview of the neurobiology of aggression, including the relevant parts of the brain and the neurotransmitters involved. Following that, we will examine how that neurobiology has been influenced by the other factors in the course, beginning with the hormones that may have altered the functioning of neurons one second before the aggressive act occurred, through the other factors, and ending with the evolution of aggression.

Lecture Nineteen

The Neurobiology of Aggression I

Scope: This lecture introduces this module by first briefly considering what is unique (and what is not) about human aggression when surveying the animal kingdom. The main topic, however, will be the neural bases of aggression—first the neurochemistry of aggressive behavior, then the neuroanatomy of it, with an emphasis on the limbic system and the frontal cortex, which often reins in limbic activity.

Outline

- I. Let's begin with a summation.
 - A. What have we accomplished so far? We have studied the biological components of behavior from a single neuron to neuronal networks to the many parts of the brain, and we have studied other disciplines that help us better understand human behavior. We have emphasized, throughout the course, the importance of the interaction and interdependency of these disciplines.
 - B. Next, we move to an attempt at further integration in studying the neurobiology of aggression.
- II. What do we mean by aggression?
 - A. If we look at human aggression in the context of other animals, we need to ask if we are the only species that:
 1. Kills? No.
 2. Kills infants? No.
 3. Has organized group violence? No.
 - B. Animal reins on aggression include hierarchies (including bottom-up ones) and reconciliation.
 - C. We do see some human specialties when it comes to aggression.
 1. We can communicate aggression with abstraction over space and time.
 2. Some people display sexual aggression.
 3. We have created a technology of aggression, going beyond muscle and teeth to intentional invention of tools of destruction.
 4. We have developed organized aggression above the level of a local band.
 5. We exhibit passive aggression.
 - D. This is a difficult subject because we all know the pleasures of a well-timed act of aggression.
- III. We continue by implicating the limbic system in aggression.
 - A. The Kluver-Bucy syndrome was an experimental technique that was done on laboratory animals in the 1930s, whereby a region of the limbic system was removed.
 - B. Such animals displayed abnormal sexual behavior and odd levels of aggression.
- IV. The amygdala is highly relevant and highly implicated in studying aggression.
 - A. Some of the experimental techniques that have implicated the amygdala include creation of brain lesions, stimulation, recording, and functional brain imaging.
 - B. Another implication of the amygdala in aggression is the study of Charles Whitman, a mass murderer in the 1960s. When he was autopsied after he killed himself, he was found to have an amygdaloid tumor.
 - C. What are the inputs to and outputs from the amygdala? (Figure 19a)
 1. Inputs include stress hormones, pain, and filtered and unfiltered sensory information.
 2. Outputs include projections to the brain regions that regulate the sympathetic nervous system, stress hormone release, and motoric output.
 - D. Is the amygdala about aggression or about fear and anxiety? (Figure 19b)
 1. Fear conditioning and the amygdala show that you can learn fearful responses.

2. Stress can lead to amygdaloid expansion and posttraumatic stress disorder.
 3. As we saw in Lecture Eighteen, amygdaloid activation when we see a person of another race is not a hard-wired fear but can be conditioned.
- E. Sexual arousal and amygdaloid activation in males may provide a link to sexual violence.
- V. Other brain structures are relevant in our study of aggression.
- A. The septum puts the metaphorical brake on aggression, working in opposition to the amygdala.
 - B. The lateral hypothalamus was thought for decades to be tied to aggression. More recently, however, this part of the brain has been found to be related to feeding (including predatory hunting) rather than to aggression.
 - C. Hindbrain and brainstem structures become metabolically active and cause arousal during both extremely violent states and greatly euphoric states, hence the famous quote from Nobel Laureate Elie Weisel: “The opposite of love is not hate. The opposite of love is indifference.”

Further Reading:

For excellent introductions to the topic of the neurobiology of aggression:

R. Nelson, *Handbook of Biology of Aggression*.

D. Niehoff, *The Biology of Violence*.

For further coverage of the topic:

M. Konner, *The Tangled Wing: Biological Constraints on the Human Spirit*.

Questions to Consider:

1. In what ways are human patterns of aggression distinctive, and in what ways are they just like those in other animals?
2. What is the evidence implicating the amygdala in aggression, and how is this intertwined with its role in responding to fear?

Figure 19a

Inputs and Outputs of the Amygdala

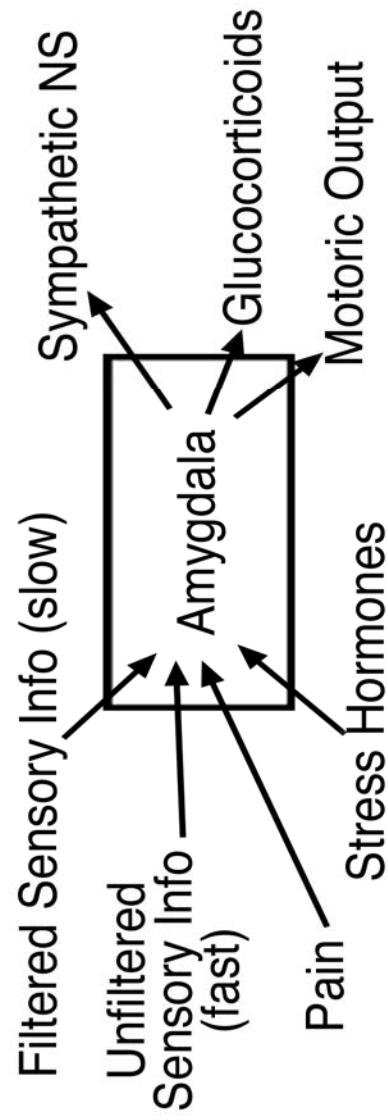

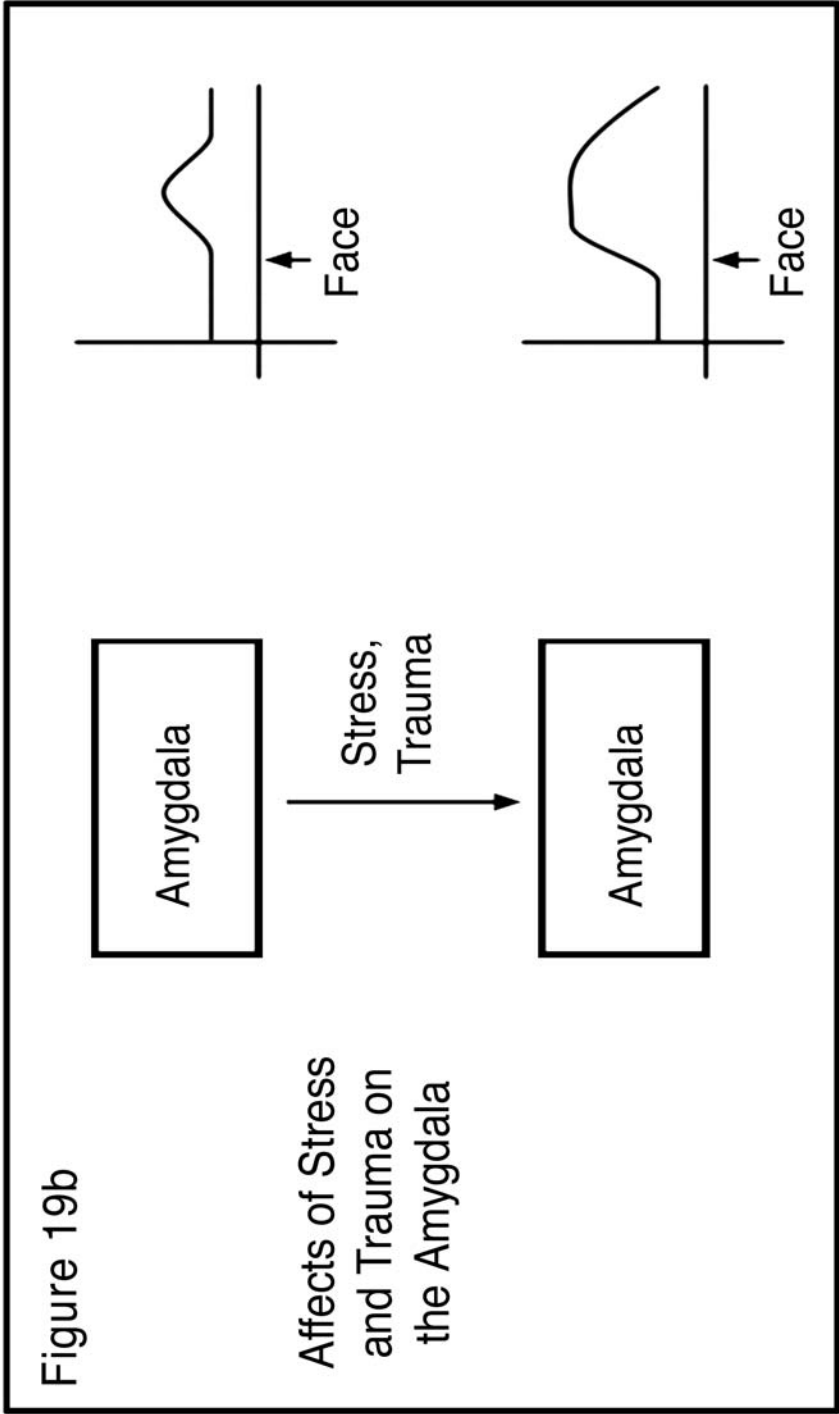

Lecture Twenty

The Neurobiology of Aggression II

Scope: This lecture poses two questions: First, what environmental events can trigger the limbic system into aggressive behavior seconds to minutes later? Next, how do hormones modulate the sensitivity of the brain to those environmental triggers? This portion of the lecture focuses heavily on the effects of reproductive hormones in both sexes, with the surprising conclusion that testosterone has less to do with aggression than most people assume.

Outline

- I.** The critical role of the frontal cortex is to get you to do the harder thing. (Figure 20a)
 - A.** First, we look at doing the harder thing in the cognitive realm.
 1. Executive function helps you strategize what to do with facts. It is your working memory.
 2. Reversal tasks, such as reciting months and numbers backwards, reveal how difficult it is to overcome ingrained patterns.
 3. Neurons of the frontal cortex activate in response to rules rather than in response to specific examples.
 - B.** Next, we look at doing the harder thing in the realm of emotional regulation and emotional disinhibition
 1. Phineas Gage, a railroad worker in the 1840s, suffered a frontal cortical lesion in a serious accident. Overnight, he changed from a sober man to a profane, aggressive, socially inappropriate man who could never work again. The loss of his frontal cortex meant he lost his emotional regulation; he had no means to do the “harder thing.”
 2. Frontotemporal dementia and stroke damage to the frontal cortex may cause inappropriate, disinhibited behaviors.
 3. The frontal cortex goes offline during rapid eye movement (REM) sleep, which explains why dreams are often wild and unrepressed.
 4. Frontal hyperactivity can result in repressive personalities—individuals with tightly regulated emotions.
 - C.** Finally, we look at doing the harder thing in the realm of behavior.
 1. We saw in Lecture Twelve the role of frontal cortical activation during decision making and gratification postponement. (Figure 20b)
 2. The study of frontal function in violent sociopaths reveals two very interesting results.
 - a. These individuals often exhibit abnormally low basal activity or histories of frontal damage.
 - b. They also often exhibit abnormally high activity when engaged in an executive task—in other words, they need to activate more of the frontal cortex than other people in order to regulate their behavior appropriately.
 - D.** The frontal cortex among primates is fairly large and well developed, but humans have a uniquely large frontal cortex.
 - E.** The study of the frontal cortex and development in humans has also been revelatory.
 1. Children are frontally disinhibited beings.
 2. Adolescents still are frontally disinhibited beings because of the remarkably late maturation of the frontal cortex.
 3. With this in mind, we need to ask if a 16-year-old violent criminal is, by definition, organically impaired in frontal cortical function.
- II.** The frontal cortex and its interactions with other brain regions are important to our understanding of aggression.
 - A.** The frontal cortex is an inhibitor of the amygdala.
 - B.** Conversely, the amygdala sends inputs to the frontal cortex to do the easier thing.

- C. Serotonergic projections are also sent into the frontal cortex and play a role in inhibiting impulsive behavior. Therefore, low serotonin levels are associated with impulsive aggression.
 - D. The dopamine projection is sent from the ventral tegmentum into the frontal cortex.
 - 1. Dopamine is the neurotransmitter of pleasure or, more correctly, of the anticipation of pleasure.
 - 2. Dopamine, metaphorically, fuels the ability of the frontal cortex to hold out for the harder thing.
- III. A subtlety of frontal cortical function during aggression merits discussion.
- A. Sometimes inhibiting aggression is a case of doing the harder thing, as when you are angry and wish to lash out but control yourself.
 - B. On the other hand, there are situations in which being aggressive is a case of doing the harder thing, as in wartime when you must choose to fight amid a strong incentive to flee.
- IV. What releasing stimuli bias the nervous system toward aggression?
- A. Fear, pain, stress, and frustration are all routes for decreased dopamine transmission.
 - B. The role of alcohol in violence has been overrated; alcohol causes violence in individuals already prone to violence.
 - C. Likewise, the role of crowding has been overrated. Like alcohol, crowding causes violence in individuals already prone to violence.
- V. We also need to look at acute hormonal effects on the neurobiology of aggression, particularly the key role of testosterone in male aggression.
- A. Correlative evidence gives us the first clues.
 - 1. Testosterone levels and levels of aggression are a function of gender, age, and season.
 - 2. There are a lot of testosterone receptors in the amygdala.
 - B. Causal evidence includes the euphemistically termed *subtraction* and *replacement* approaches.
 - 1. With subtraction, the testes are removed from a male, and his aggression levels are found to go down.
 - 2. With replacement, after removal of the testes, the male's testosterone is replaced by synthetic testosterone, and his aggressive behavior returns.
 - C. We now have evidence that shows the limited role of testosterone in aggression. (Figure 20c)
 - 1. Castration reduces but does not eliminate aggression.
 - 2. The more precastration aggressive experience an individual has, the greater the amounts of his postcastration aggression.

Further Reading:

For a masterly introduction to the role of the frontal cortex in emotional regulation:

A. Damasio, *Descartes' Error: Emotion, Reason, and the Human Brain*.

For a review of the cognitive aspects of frontal function:

I. Wishaw and B. Kolb, *Fundamentals of Human Neuropsychology*, 5th ed.

For the subject of hormones and aggression:

J. Becker, M. Breedlove, D. Crews, and M. McCarthy. *Behavioral Endocrinology*, 2nd ed.

R. Nelson, *An Introduction to Behavioral Endocrinology*, 2nd ed.

Questions to Consider:

- 1. What are the ways in which the frontal cortex causes us to do the "harder thing"?
- 2. How might individual differences in limbic and frontal cortical function explain individual differences in aggression?

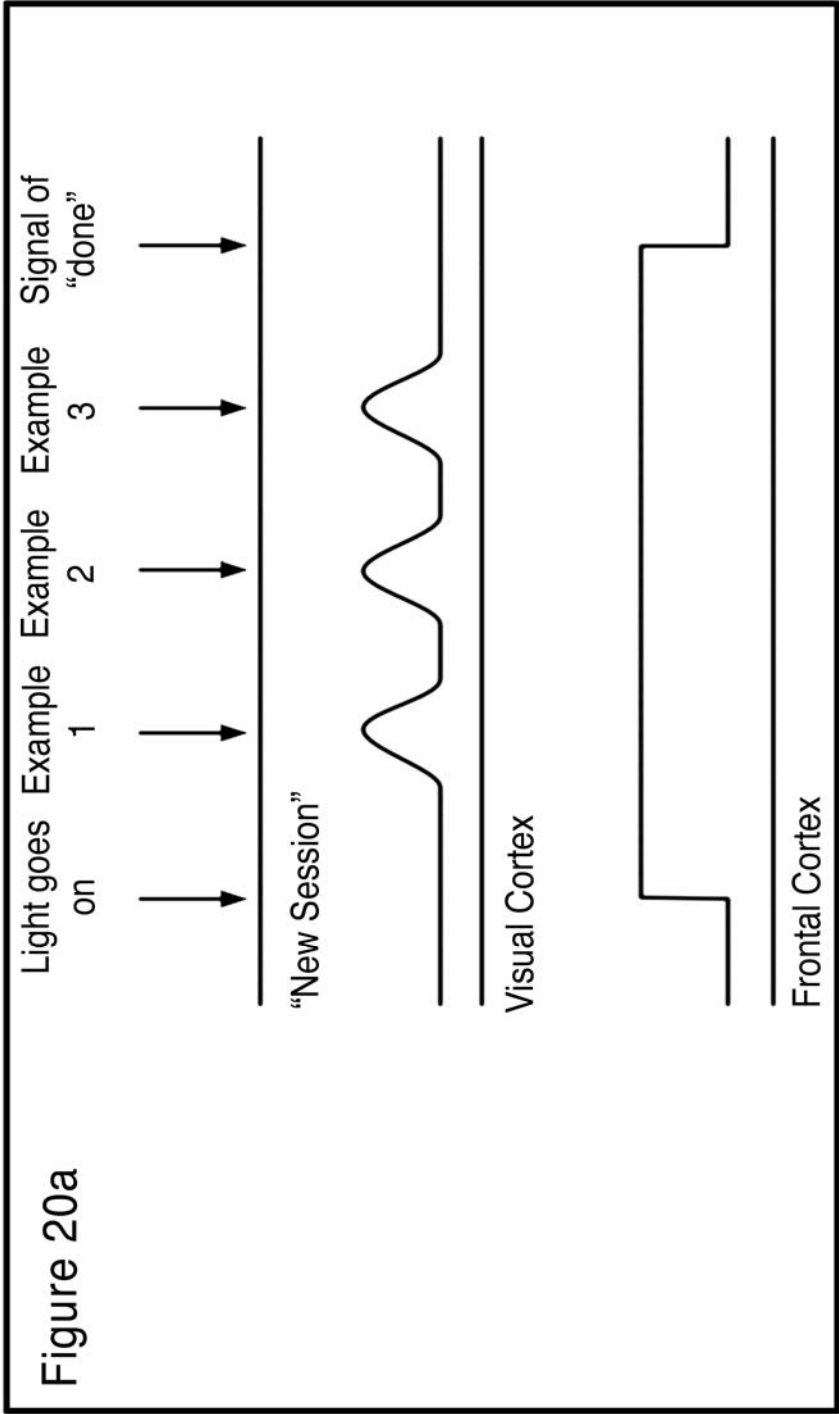

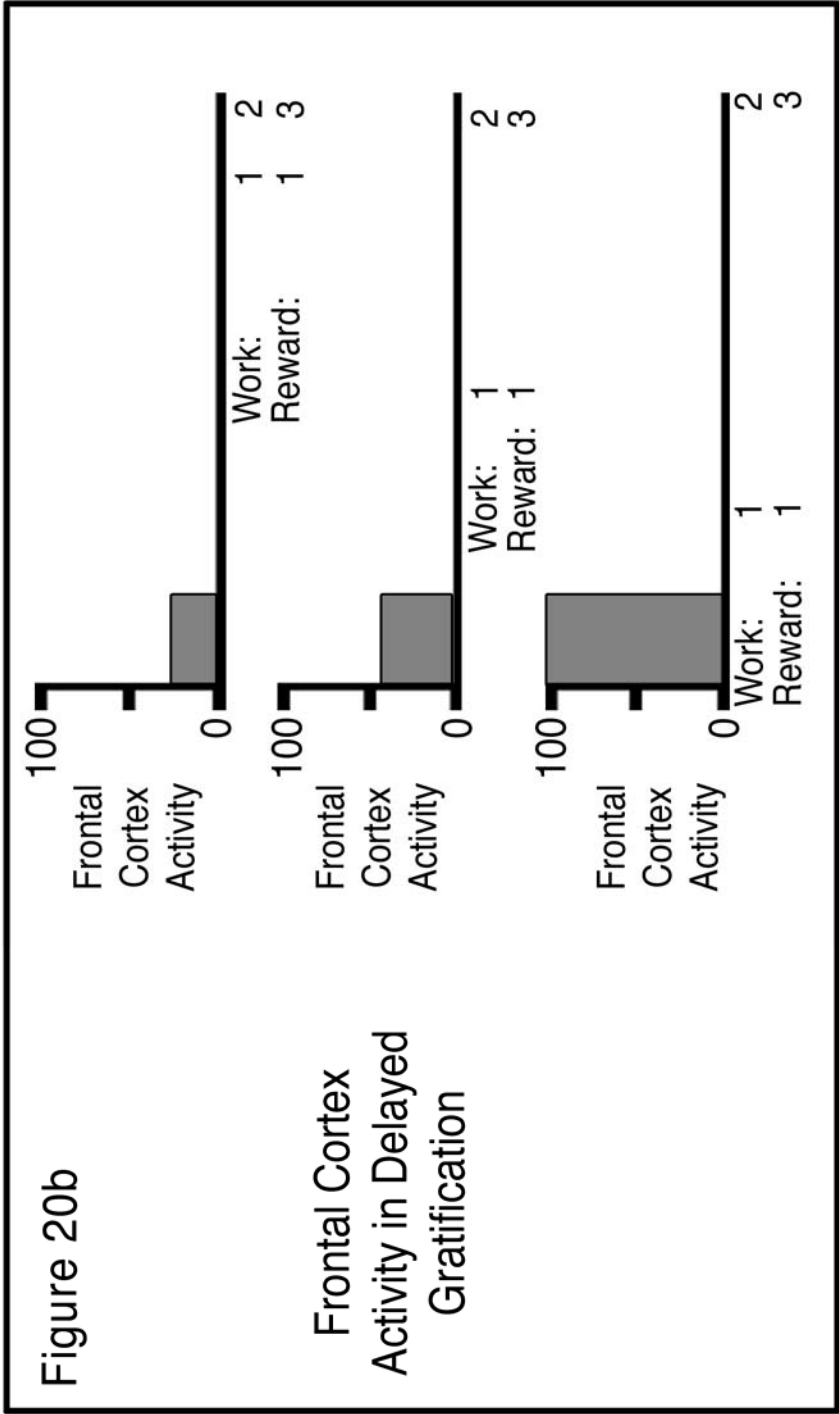

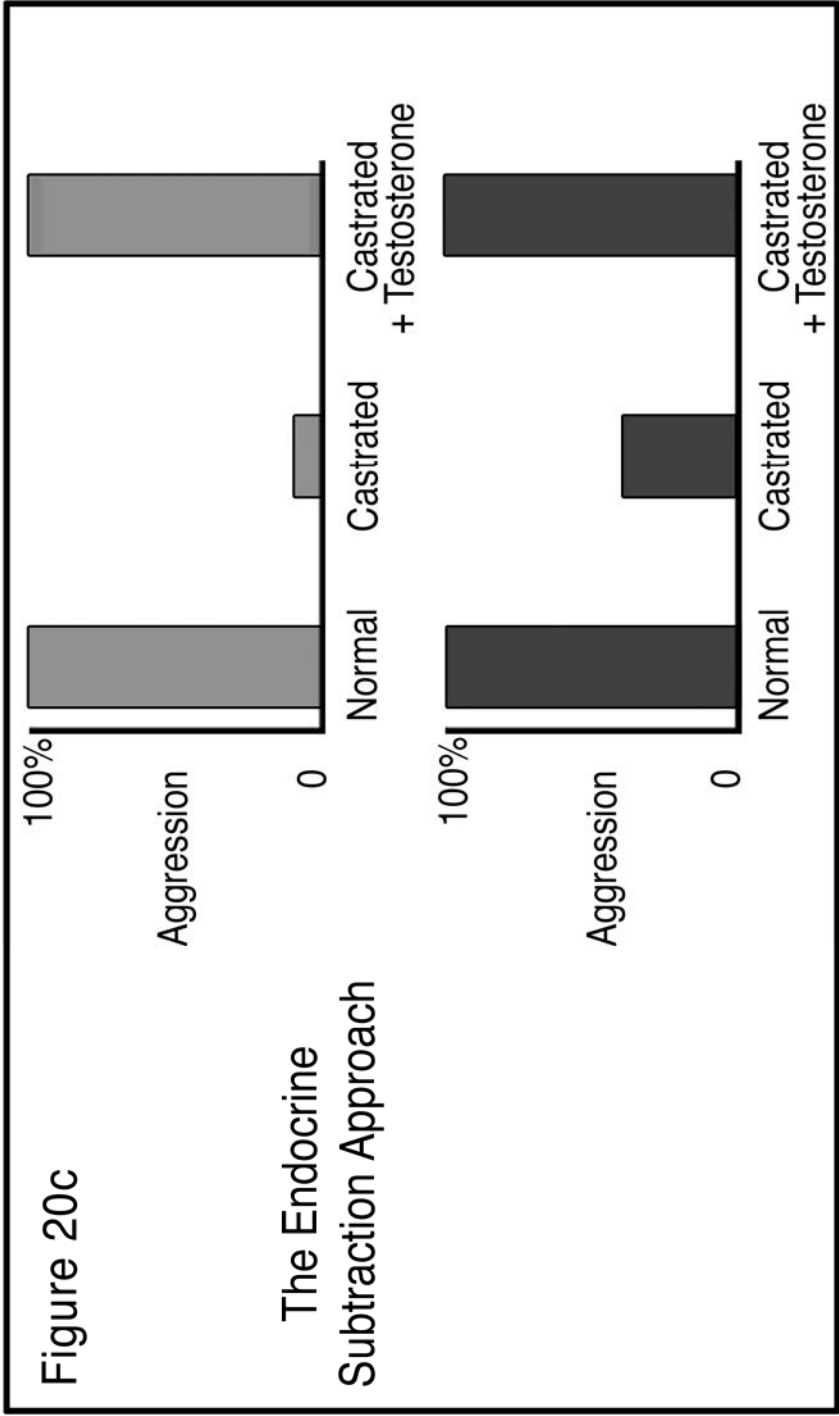

Lecture Twenty-One

Hormones and Aggression

Scope: This lecture expands the time-course of Lecture Twenty in another way, asking how patterns of hormone exposure around the time of birth can influence adult patterns of aggression. The second part of the lecture focuses on an even longer-term physiological influence, namely, genes. The punch line in considering this contentious subject is that genes may have something to do with the neurobiology of aggression but never outside the context of strong environmental interactions.

Outline

- I. Does testosterone cause aggression?
 - A. The answer relates to the metaphor of increasing the volume of the radio playing martial music, rather than turning on the radio in the first place.
 - B. Neurobiological evidence states that testosterone does not activate amygdaloid neurons (turn on the radio) but, rather, makes amygdaloid neurons that are already excited more excitable (turn up the volume).
- II. Do individual differences in testosterone levels explain individual differences in levels of aggression? (Figure 21a)
 - A. Fluctuation in testosterone levels within the physiological range does not generally cause changes in aggression.
 - B. But there is a consistent correlation between the two, with aggression elevating testosterone levels, rather than the other way around.
 - C. Testosterone levels above the normal range may result when someone takes anabolic steroids.
 - D. The conclusion is that one hormone cannot explain aggression. A striking example of proof comes from studying murder rates in London, Toronto, and Detroit. In men in all three cities, the highest levels of aggression were found to occur at the same ages (late adolescence/ young adulthood). However, amid that similarity, there were enormous differences in the absolute number of murders among the three cities, showing the importance of environment in aggression. (Figure 21b)
- III. We also need to look at hormones and female aggression.
 - A. Testosterone-related (androgenic) hormones come from the adrenal gland.
 - B. Estrogen and progesterone are also relevant for female aggression.
 1. The ratio of the two is more important than the levels.
 2. Fluctuating ratios around menstruation have been tied to patterns of criminal behavior in women during the perimenstrual period.
 3. Fluctuating ratios around parturition explain why you do not pick up cute newborn kittens when their mother is nearby.
- IV. We must also consider stress hormones and aggression in both genders.
 - A. Sympathetic nervous system activity is a nonspecific marker in aggression.
 - B. Glucocorticoids can have two interesting yet disturbing effects.
 1. Glucocorticoids can cause enhancement of amygdaloid function, leading to posttraumatic stress disorder.
 2. Glucocorticoids can cause disruption of frontal cortical function, causing us to make imprudent decisions in moments of stress.
- V. Some major theories about environmental factors in aggression are worthy of consideration.
 - A. The Lorenzian notion that aggression is universal, inevitable, and self-depleting is not tenable.

- B. Marxist models of aggression are based on fear and resource inequity, but many types of animal aggression have been identified when resources are plentiful.
- C. The behaviorist view was that the right reinforcement schedule can make aggression disappear, but a 225-year-long experiment partially refutes this view: The death penalty tends to drive down instances of premeditated violence, but it has little effect on impulsive violent behavior.

VI. We now turn to child development, aggression, and empathy.

- A. The differentiation of the self in toddlers is key.
 - 1. Ego boundary issues exist because a toddler is distinguishing where his mother ends and he begins as an individual.
 - 2. Studies have shown that other species have a self-concept as well.
- B. The emergence of *theory of mind* is the recognition that other individuals have other thoughts and knowledge than you.
 - 1. Human versions display a recognition that others have different feelings, needs, and capacities for pain than oneself.
 - 2. Nonhuman primate versions have shown that a chimpanzee can understand what information another chimpanzee has and can shape its behavior accordingly.
- C. The emergence of empathy begs the question as to whether theory of mind is necessary and/or sufficient to give rise to that quality. What appears to be empathy in toddlers, who do not yet demonstrate theory of mind, may instead be an expression of ego boundary problems or distress reduction.
- D. The learning of rules about the appropriate context for aggression often drives development.
 - 1. We have seen the Harlow studies of social isolation in young primates in Lecture Eighteen.
 - 2. Learning your rank as a social primate is part of growing up. Primates who grow up without a mother to show them the rules may be inappropriately aggressive.
 - 3. Scientists have also studied whether early exposure to violence begets later violence, thus legitimizing its rationales and habituating to its harmful consequences.
 - a. Childhood abuse studies show that adults who are child abusers tend to have been abused as children, but most children who are abused do not grow up to be child abusers.
 - b. Television violence increases violence in those children who are already prone toward it.
 - c. Being raised in cultures with credos of victimization and justified revenge is more likely to lead to socially inappropriate behavior.
 - d. Being raised in authoritarian cultures, with emphases on externalizing of blame, on conforming, and on rigid, unreflective cognitive styles is also more likely to lead to socially inappropriate behavior.

Further Reading:

For the subject of hormones and aggression:

J. Becker, M. Breedlove, D. Crews, and M. McCarthy, *Behavioral Endocrinology*, 2nd ed.

R. Nelson, *An Introduction to Behavioral Endocrinology*, 2nd ed.

For thorough coverage of some of the theories about the nature of aggression:

M. Konner, *The Tangled Wing: Biological Constraints on the Human Spirit*.

For two classics in the field of moral development in children:

R. Coles, *The Moral Intelligence of Children: How to Raise a Moral Child*.

W. Damon, *Moral Child: Nurturing Children's Natural Moral Growth*.

Questions to Consider:

1. Why should hormones be thought of as modulators of aggressive tendencies in the brain rather than as activators of such tendencies?
2. How can theories about environmental modulators of aggression be translated into neurobiological terms?

Figure 21a

Testosterone and Aggression

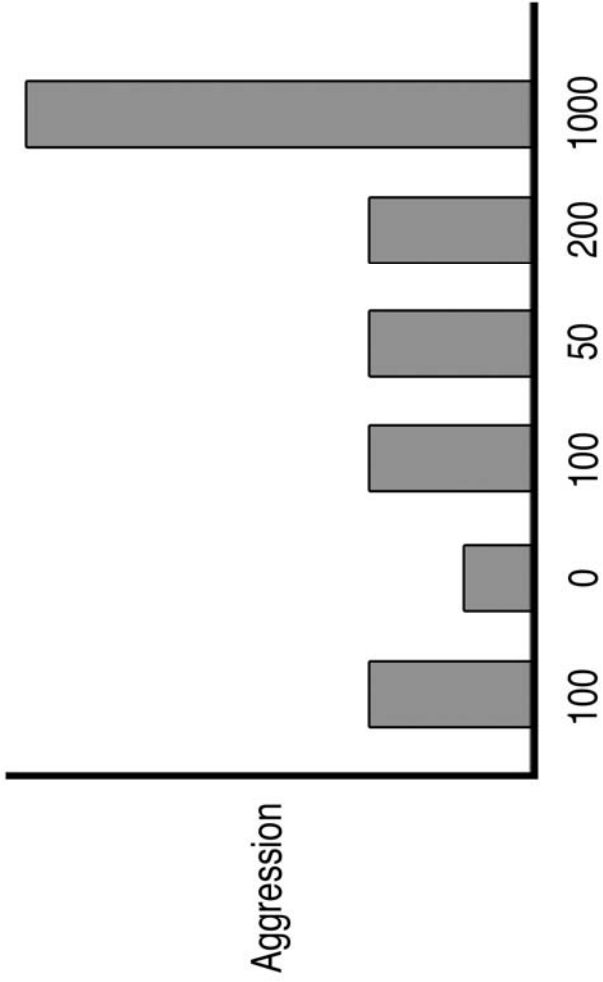
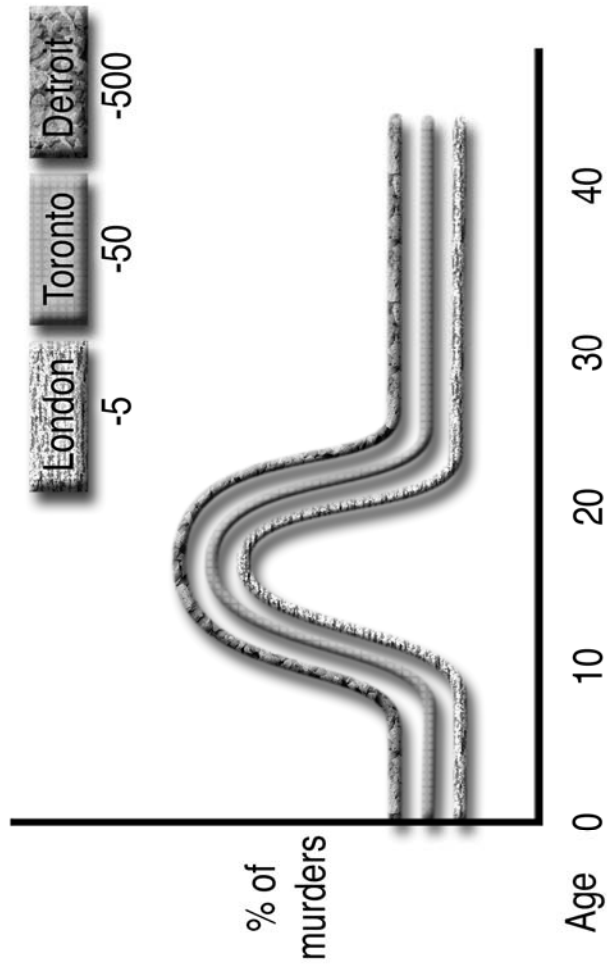

Figure 21b

Murder Rates



Lecture Twenty-Two

Early Experience and Aggression

Scope: This lecture also expands the time-course of Lecture Twenty, now examining how environmental factors can influence aggression occurring days to decades later. We will look at the neurobiology of reward and punishment (and the effect of either on aggression), of the ways in which adult aggression can be modulated by early experience and social learning, and of the ways in which those early experiences can shape the development of relevant parts of the brain.

Outline

- I. We now look at moral development in children. (Figure 22a)
 - A. Kohlberg's three stages of moral development were based on the immediacy of punishment.
 1. In the Pre-Conventional stage, moral behavior is about the immediate consequences.
 2. In the Conventional stage, the individual leaps into the realm of societal rules and conventions. Individuals see the consequences of their actions down the road ("I'll eventually get caught" or "What if everybody did this?").
 3. In the Post-Conventional stage, the sense of morality is that the right thing is independent of contracts and rules and convention. Actions are based more on simply deciding to do the right thing, no matter what the laws or consequences are. Some people never attain that stage.
 - B. Critiques of Kohlberg say that the stages fit males more than females and are culturally biased as well, being quite Eurocentric.
 - C. Does one's Kohlberg stage actually predict anything about behavior? Not especially.
 1. Does it help us predict who will step out of a crowd to do the hard but right thing? Not particularly.
 2. A better predictor is doing moral acts as a frequent childhood imperative.
 - D. How do we frame the possible neurobiological underpinnings of moral developmental stages?
 1. Is climbing up the Kohlberg ladder merely a function of getting a more mature frontal cortex that has more and more potentiated pathways and is more adept at gratification postponement?
 2. Yet most advanced stages of moral development seem outside the purview of the frontal cortex. This is the realm where no degree of gratification postponement can explain doing the harder thing; this is because there is no gratification, and instead, you may be punished for doing the harder but right thing.
 3. Reflexive moral acts and implicit neural pathways outside the frontal cortex are still a mystery.
- II. Another issue is development and adolescent male aggression.
 - A. We know by now to be wary of the correlation between a peak in aggression during adolescence in males and a peak in testosterone levels. Remember the study of aggression in young males in London, Toronto, and Detroit in Lecture Twenty-One.
 - B. A peak in alcohol-related aggression has been studied in alcoholics.
 - C. Cross-cultural differences in aggression dwarf developmental patterns. Again, remember the study of aggression in young males in London, Toronto, and Detroit.
 - D. A nonhuman primate example of this idea is the cultural transmission of a baboon troop's social tradition of low aggression.
- III. Another predictor of adult antisocial behavior is being an unwanted child.
- IV. We now shift to study long-term physiological effects in the form of perinatal hormones.
 - A. We look first at *organizational* effects of hormones during perinatal life as opposed to *activational* effects during adulthood.
 - B. The organizational effects of androgens on subsequent aggression are of great interest.

1. Rodent studies (such as fetal positioning), as we saw in Lecture Sixteen, show that prenatal testosterone masculinizes patterns of aggression and makes for individuals, including females, who are more aggressive and more easily provoked toward aggression.
 2. Primate studies show the same results.
 3. Congenital adrenal hyperplasia in human females is the result of being exposed to a lot of testosterone prenatally. These girls grow up to display higher than expected levels of aggression and less interest in gender-specific toys. However, they also have been exposed to multiple painful and embarrassing surgeries and often are treated differently by parents because of their ambiguous gender, all of which may affect behavior.
- V. Now we shift one step further back and look at the long-term physiological effects of genes.
- A. This is a dirty concept in many quarters, implying the shadows of eugenics and of washing one's hands of unappealing behaviors.
 - B. Yet there must be a genetic component to aggression. Otherwise, why you would trust your baby to a beagle more readily than to a pit bull?
 - C. What genes are likely to be relevant to aggression? The answer is those genes related to pain thresholds, frustration thresholds, impulsivity, sensation-seeking, and emotional regulation.
 - D. In that context, a number of genes that have been implicated in aggressive behavior relate to neurotransmitter systems—genes that are relevant to many other realms of behavior as well.
 - E. We can consider a model for how genetic influences might work.
 1. As a review, we saw in Lecture Sixteen a study of a large population of children that showed a correlation between serotonin and depression in certain environments.
 2. Further study was done of different versions of genes relevant to serotonin synthesis, degradation, transport, and so on.
 3. It was found that a certain gene variant or monoamine oxidase (MAO) is predictive of antisocial behavior in humans but only when coupled with a childhood history of abuse. (Figure 22b)
 - F. Let's end the lecture by debunking an urban myth about genes and aggression. While in prison, Richard Speck, a mass murderer from the 1960s, was discovered to be an XYY male instead of a normal XY male. This prompted the idea that XYY males were genetically prone toward violence, an idea not supported by evidence.

Further Reading:

For a summary of Kohlberg's work:

L. Kohlberg, *The Psychology of Moral Development: The Nature and Validity of Moral Stages*.

For additional readings about moral development in children:

R. Coles, *The Moral Intelligence of Children: How to Raise a Moral Child*.

W. Damon, *Moral Child: Nurturing Children's Natural Moral Growth*.

For the subject of early endocrine exposure and aggression:

J. Becker, M. Breedlove, D. Crews, and M. McCarthy, *Behavioral Endocrinology*, 2nd ed.

R. Nelson, *An Introduction to Behavioral Endocrinology*, 2nd ed.

For coverage of the extraordinarily controversial subject of genetics and aggression:

R. Lewontin, *It Ain't Necessarily So: The Dream of the Human Genome and Other Illusions*.

R. Plomin, *Behavioral Genetics*, 3rd ed.

Questions to Consider:

1. How can the development of moral thought and action in children be shaped by the particulars of their upbringing, and how can this be translated into neurobiological terms?
2. How is the genetics of aggression about propensities and vulnerabilities, rather than about inevitabilities?

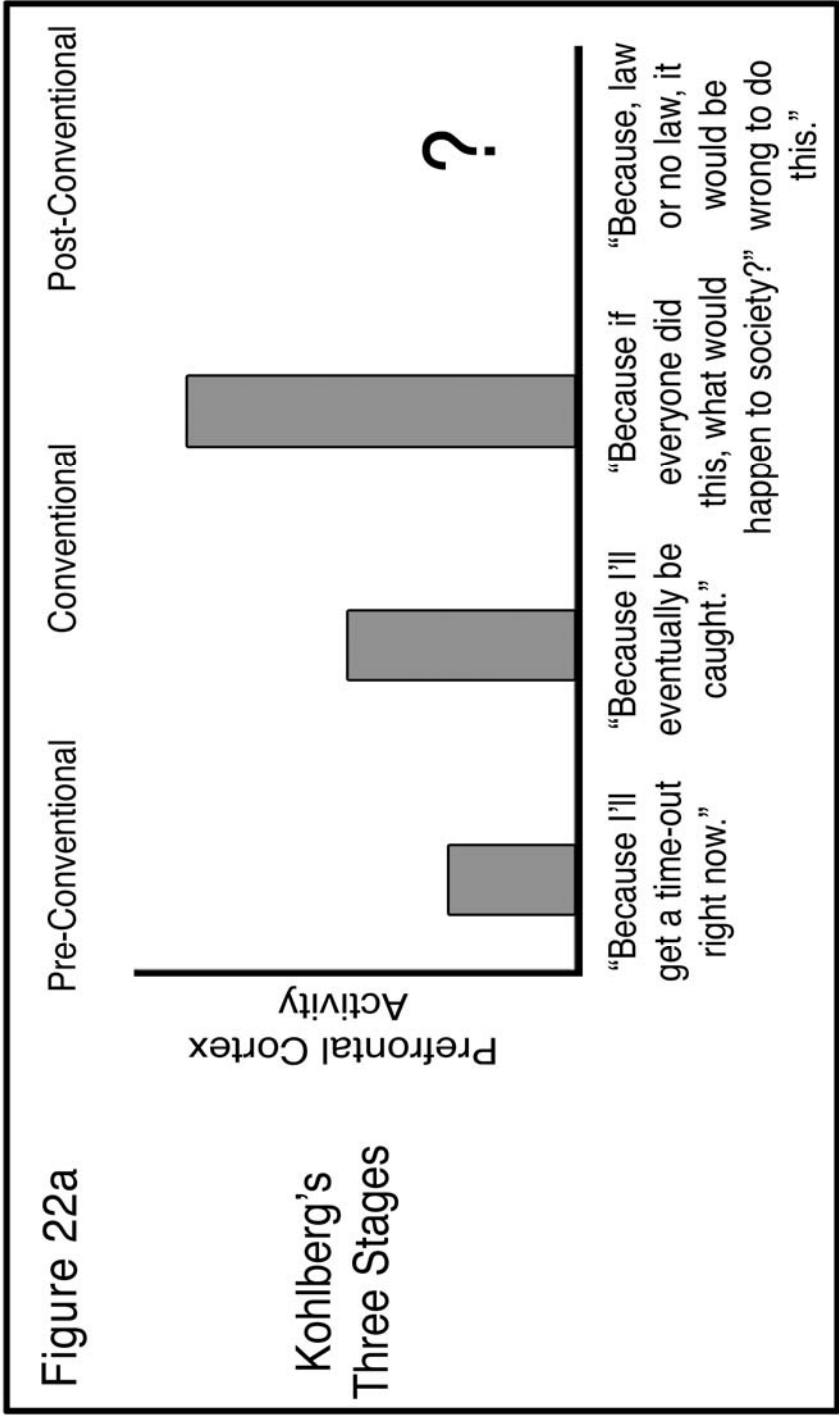

Figure 22b

<u>Version of MAO</u>	<u>Early Environment</u>	<u>Antisocial Behavior</u>
Good	+ Good	= Low
Good	+ Abusive	= Low
Bad	+ Good	= Low
Bad	+ Abusive	= HIGH

Lecture Twenty-Three

Evolution, Aggression, and Cooperation

Scope: The final lecture in this module expands the time-course even further, now asking how the biology of aggression—limbic function, hormones, sensitivity to environmental influences, genes—evolved. The lecture examines which evolutionary factors bias toward aggression occurring and, even more important, how evolutionary biology gives us insights into how aggression might be contained.

Outline

- I. Let's begin by looking at some ecological correlates of aggression.
 - A. Warrior classes and high levels of aggression are more common among pastoralists than among agriculturalists.
 - B. Organized aggression is also more common among desert dwellers than among rainforest dwellers.
- II. Why ever be aggressive? Let's rethink Marlin Perkins's claim that animals behave for the good of the species.
- III. Individual selection and its propagation of aggression disprove Perkins's notion and provide the first bad news about evolutionary biology.
 - A. Male-male aggression for reproductive access to females is a common form of violence in primate species, including humans.
 - B. Competitive infanticide offers the most heartbreaking evidence against group selection.
- IV. Kin selection helps explain us/them dichotomies and the roots of xenophobia.
 - A. We have seen the results of kinship and cooperative aggression among male chimpanzees.
 - B. We also see kinship and organized aggression in patrilocal human societies.
- V. Humans, pseudokinship, and pseudospeciation merit examination as well.
 - A. Lots of species recognize a relative through innate recognition of sensory information.
 - B. Humans recognize relatives through cognitive routes.
 - C. An implication of this fact is that a human's sense of relatedness can be manipulated.
 - D. An example of such manipulation is the sociological concept of pseudokinship and the idea of "bands of brothers."
 1. Military rituals throughout human cultures build such a bond.
 2. The unprecedented pseudokinship of American troops in World War II underscores the strength of this bond.
 - E. The flip side of pseudokinship is pseudospeciation, where enemies are portrayed as hardly counting as human.
- VI. Let's now look at the first piece of good news that arises from kin selection.
 - A. If you can pseudospeciate someone into being an enemy, you can pseudokinship back from that state.
 - B. Rituals of pseudokinship among ex-enemies prove that this change is possible.
 - C. We saw another example of this transformation in Lectures Eighteen and Nineteen, where we found that viewing strangers as individuals rather than categorically helped tame the amygdala.
- VII. More good news is found in studies of alternative strategies among males in the primate world.
 - A. Studies were done of groups of baboons in which male-female affiliation, rather than male-male competition, drives who females choose to mate with.
 - B. Reproductive success among such male baboons has shown that this is a successful evolutionary alternative.

VIII. More good news is evident in reciprocal altruism and cooperation.

- A. Back in Lecture Twelve, we learned about the Prisoner's Dilemma and the strategic advantages of cooperation.
- B. We also discussed how to jumpstart cooperation in game theory settings, looking at the effects of inbred populations, multiple rounds of games, reputation, punishment of cheaters, and choice of partners as circumstances that increase the likelihood of increasing cooperation.
- C. Whatever the route, reciprocal altruism and cooperation can emerge, even in the most inauspicious of circumstances.
 - 1. A vivid example occurred during World War I, with the Christmas truce and spontaneous mutual restraint in trench warfare.
 - 2. Maybe, just maybe, there is hope.

Further Reading:

For the subject of the evolution of aggression and nonaggression:

J. Becker, M. Breedlove, D. Crews, and M. McCarthy. *Behavioral Endocrinology*, 2nd ed.

M. Konner, *The Tangled Wing: Biological Constraints on the Human Spirit*.

R. Nelson, *Handbook of Biology of Aggression*.

D. Niehoff, *The Biology of Violence*.

Questions to Consider:

- 1. What are the ways in which contemporary evolutionary thinking helps explain patterns of aggression?
- 2. What are the ways in which contemporary evolutionary thinking gives insights into the control of aggression?

Lecture Twenty-Four

A Summary

Scope: This final lecture presents a summary of what we have learned about the neurobiology of our individual differences. The main point, however, will be to explore the implications of this knowledge. Some of the consequences are societal in nature. For example, how much should we worry about the misuse of information in behavioral biology—the temptation to use this knowledge to label and pathologize and to try to fix things that are not broken? And even more fundamentally, what are the philosophical implications of this field? How much do insights into the neurobiology of our behaviors threaten our sense of self and individuality?

Outline

- I. How are we to understand this emerging biology of what makes us who we are?
 - A. We must draw a distinction between the essence of who a person is and the biology that can constrain and distort that essence.
 - B. We must be careful in deciding when that distinction is readily made and when it is not.
- II. An examination of some subtle neuropsychiatric disorders underscores the difficulty of such a distinction.
 - A. We have discussed the effects of frontal cortical damage numerous times.
 1. In Lecture Twenty, we heard about the effects of damage to the frontal cortex in Phineas Gage.
 2. We have learned that frontotemporal dementia may cause inappropriate, disinhibited behaviors.
 - B. Obsessive-compulsive disorder is a debilitating neuropsychiatric disorder.
 1. Its features include ritualistic counting, obsessive hand-washing, and constant and repeated checking to ensure that one has completed common activities, such as locking the door or turning off the gas.
 2. We see here an emerging neurobiology of elevated metabolism in motoric parts of the brain.
 - C. Tourette's syndrome is a disorder with symptoms that include uncontrollable cursing, facial ticks, yelps, and inappropriate gestures. It has received a lot of attention in neuropsychiatric circles lately.
 1. This is not a disinhibition of the self. It has been termed "hiccups of the id."
 2. Here we see emerging neurogenetics of the disease.
 - D. Schizotypal personality disorder is a mild version of schizophrenia.
 1. It is on a genetic and symptomatic continuum with schizophrenia.
 2. Its symptoms include social withdrawal, concreteness in interpretation of events, and metamagical thinking.
 3. Is it a mental illness to consult astrologers? No, these traits are the extremes of normative thinking.
 - E. Temporal lobe personality disorder is a subtype of epilepsy.
 1. In temporal lobe epilepsy, seizures start in the temporal lobe, which is part of the limbic system.
 2. Among the disorder's symptoms is an obsession with religious and philosophical subjects.
- III. Then comes the challenge of this new information.
 - A. What happens when we each have a few of these labels?
 - B. What happens when this science stops being about the biology of "them and their diseases" and becomes the biology of "us and our individuality"?
- IV. Some societal implications are inevitable.
 - A. The downside may be devastating.
 1. If you get one of these labels and you are poor or poorly connected, there are great precedents for you now being treated poorly by society.

2. The temptation to “fix what ain’t broken” is a historical force of evil in biology. The important questions are: What counts as being ill? Who is biologically impaired, and who is just different?
- B.** But there is an optimistic side as well.
1. We can strive to reach new realms of compassion in dealing with debilitating psychiatric diseases and disorders.
 2. We can work to develop pseudokinsip through neurobiology, including the recognition of continua of disorder symptoms and a reality of “There but for the grace of God go I.”
 3. Finally, perhaps we will someday acknowledge that being healthy consists of having the same diseases as everyone else and the same values as to what is a disease and what is healthy, what is normal and what is abnormal.
- V.** Some philosophical implications are equally important.
- A.** What will these biological insights do to our treasured sense of uniqueness? As science explains more and more about less and less, will we all be explained as no more than a mass of neurons and hormones, no longer special and different? As in the story *Nine Billion Names of God*, will the stars in the heavens be extinguished because science will have explained everything in our universe?
 - B.** Such scientific explanations and progress should not be feared.
 1. To explain something is not to destroy the capacity to be moved by it. And certainly, we can never explain everything, because every answer opens up a dozen new questions.
 2. To paraphrase Haldane, “Life is not only stranger than we imagine, life is stranger than we can imagine.”
 - C.** Thus, in the end, the purpose of science is not to cure us of our sense of mystery and wonder but to constantly reinvent and reinvigorate it.

Further Reading:

For further ruminations on this subject:

M. Konner, *The Tangled Wing: Biological Constraints on the Human Spirit*.

R. Sapolsky, *Monkeyluv and Other Essays on Our Lives as Animals*.

R. Sapolsky, *The Trouble with Testosterone and Other Essays on the Biology of the Human Predicament*.

Questions to Consider:

1. What is one example in which “normal” and “abnormal” human traits may be on a genetic continuum?
2. What are the implications of the science discussed in this course in the realm of criminal justice and accountability?

Biographical Notes

Axelrod, Robert (1943–). Economist who is a key figure in game theory/neuroeconomics, being the first to generate Prisoner's Dilemma round robins and showing the utility of the tit-for-tat strategy.

Cannon, Walter (1871–1945). One of the founders of stress physiology. Major figure in delineating the functions of the autonomic nervous system. Coined the term *fight-or-flight syndrome*.

Eldredge, Niles (1943–). Evolutionary biologist who, along with S. J. Gould, generated the punctuated equilibrium hypothesis.

Gage, Phineas (1823–1860). Famous neurological patient whose frontal cortex was destroyed in an accidental explosion.

Gould, Stephen Jay (1941–2002). Evolutionary biologist and science writer. One of the two scientists (along with Nils Eldredge) who generated the punctuated equilibrium hypothesis.

Guillemin, Roger (1924–). Nobel Laureate endocrinologist who, along with Andrew Schally, first identified the hormones with which the brain regulates the anterior pituitary.

Haldane, J. B. S. (1892–1964). Evolutionary biologist and leftist political writer.

Hamilton, William D. (1936–2000). Evolutionary biologist who, among other things, played a central role in the shift in the field away from group selection thinking.

Harlow, Harry (1905–1981). Psychologist who pioneered studies regarding the importance of maternal care and peer socialization on development in primates.

Hebb, Donald (1904–1985). Neuroscientist most closely associated with the idea that learning involves the strengthening of connections of preexisting synapses, rather than the formation of new synapses.

Hubel, David (1926–). Nobel Laureate who, along with Torsten Wiesel, did classic work showing how the cortex processes visual information.

Kety, Seymour (1915–2000). Psychiatrist who pioneered adoption studies for identifying genetic contributions to mental illness, beginning with his work on schizophrenia.

Kohlberg, Lawrence (1927–1987). Psychologist who has been the central figure in the study of moral development in children.

Lorenz, Konrad (1903–1989). Nobel Laureate who, along with Niko Tinbergen and Karl von Frisch, founded ethology. Was also a Nazi propagandist who was jailed for his activities after World War II.

McClintock, Barbara (1902–1992). Nobel Laureate who, amid decades of skepticism, pioneered the notion that genes could move around the genome (that is, transposable genetic elements).

Mendel, Gregor (1822–1884). Father of genetics who, in his classic breeding studies, pioneered the notion of dominant and recessive heritable traits.

Moniz, António Caetano de Abreu Freire Egas (1874–1955). Nobel Laureate neurologist who invented frontal lobotomies.

Papez, James (1883–1958). Neurologist who first conceived of the limbic system as an integrated brain region central to emotion.

Schally, Andrew (1926–). Nobel Laureate endocrinologist who, along with Roger Guillemin, first identified the hormones with which the brain regulates the anterior pituitary.

Selye, Hans (1907–1982). One of the founders of stress physiology, playing the central role in uncovering the importance of glucocorticoid hormones in the stress response.

Skinner, B. F. (1904–1990). Psychologist and writer who was a leading figure throughout the century in advocating behaviorism.

Tinbergen, Niko (1907–1988). Nobel Laureate who, along with Karl von Frisch and Konrad Lorenz, founded ethology.

Vale, Wylie (1941–). Key figure in the characterization of various hypothalamic hormones; first to do so for CRH, the initiator of the stress response.

von Frisch, Karl (1886–1982). Nobel Laureate who, along with Niko Tinbergen and Konrad Lorenz, founded ethology.

Watson, John B. (1878–1958). Psychologist generally viewed as being the founder of behaviorism.

Wiesel, Torsten (1924–). Nobel Laureate who, along with David Hubel, did classic work showing how the cortex processes visual information.

Wilson, Edward O. (1929–). Entomologist, naturalist, and writer who, among other major contributions, is viewed as one of the central figures in the field of sociobiology.

Bibliography

Introductory Readings (not necessarily easy but should be accessible to the motivated nonscientist):

- Alcock, J. *Animal Behavior: An Evolutionary Approach*, 7th ed. Sunderland, MA: Sinauer, 2001. A great introduction to ethology.
- Barash, D. *The Survival Game: How Game Theory Explains the Biology of Cooperation and Competition*. New York: Times Books, 2003. A good introduction to game theory.
- Barondes, S. *Molecules and Mental Illness*, 2nd ed. New York: Scientific American Library, W.H. Freeman, 1999. A particularly good overview of what neurotransmitters have to do with mental illness.
- Becker, J., M. Breedlove, D. Crews, and M. McCarthy. *Behavioral Endocrinology*, 2nd ed. Cambridge, MA: MIT Press, 2002. An excellent text on neuroendocrinology, including the subjects of hormones and aggression and early endocrine exposure and aggression.
- Brown, A. *The Darwin Wars: The Scientific Battle for the Soul of Man*. London: Simon and Schuster, 1999. A good introduction to evolution and the neurobiology of behavior.
- Coles, R. *The Moral Intelligence of Children: How to Raise a Moral Child*. New York: Penguin/Putnam, 1998. A classic in the field of moral development in children. Also covers the subject of the evolution of aggression and nonaggression.
- Damasio, A. *Descartes' Error: Emotion, Reason, and the Human Brain*. New York: HarperCollins, 1994. A masterly introduction to the role of the frontal cortex in emotional regulation. Also covers the subject of the evolution of aggression and nonaggression.
- Damon, W. *Moral Child: Nurturing Children's Natural Moral Growth*. New York: Free Press, 1988. A classic in the field of moral development in children. Also covers the subject of the evolution of aggression and nonaggression.
- Kalat, J. *Biological Psychology*, 8th ed. Belmont, CA: Wadsworth Thomson Learning, 2003. A particularly good and accessible treatment of the autonomic nervous system.
- Kohlberg, L. *The Psychology of Moral Development: The Nature and Validity of Moral Stages*. New York: Harper and Row, 1984. A summary of the work of the psychologist who has been the central figure in the study of moral development in children. Also covers the subject of the evolution of aggression and nonaggression.
- Konner, M. *The Tangled Wing: Biological Constraints on the Human Spirit*. New York: Times Books/Henry Holt, 2002. Probably the most nuanced and insightful book available concerning the biology of human behavior (and beautifully written by an eminent scientist/physician). Includes in-depth coverage of aggression and the theories about the nature of aggression.
- Kruuk, H. *Niko's Nature: The Life of Niko Tinbergen and His Science of Animal Behaviour*. Oxford, U.K.: Oxford University Press, 2003. A nice biography of Tinbergen, who was truly a giant of a scientist and person.
- LeDoux, J. *The Emotional Brain: The Mysterious Underpinnings of Emotional Life*. New York: Simon and Schuster, 1996. A good reference on the limbic system.
- . *Synaptic Self: How Our Brains Become Who We Are*. New York: Penguin Books, 2002. As with LeDoux's 1996 publication, a fine book covering the limbic system.
- Lewontin, R. *It Ain't Necessarily So: The Dream of the Human Genome and Other Illusions*. New York: New York Review of Books, 2000. A very strong critique of behavioral genetics as a field by an eminent geneticist.
- MacLean, P. *The Triune Brain in Evolution: Role in Paleocerebral Functions*. New York: Plenum Press, 1990. A classic on the subject by one of the key people in the field.
- Moore, D. *The Dependent Gene: The Fallacy of Nature vs. Nurture*. New York: Times Books, 2002. An excellent introduction to the subject of macroevolution of genes and the regulation of gene expression by the environment.
- Nelson, R. *Handbook of Biology of Aggression*. Oxford, U.K.: Oxford University Press, 2005. An excellent introduction to the topic of aggression.
- . *An Introduction to Behavioral Endocrinology*, 2nd ed. Sunderland, MA: Sinauer, 2000. An excellent text on neuroendocrinology, including the subjects of hormones and aggression and early endocrine exposure and aggression.

Niehoff, D. *The Biology of Violence*. New York: Free Press, 1998. An excellent introduction to the topic of aggression.

Plomin, R. *Behavioral Genetics*, 3rd ed. New York: W.H. Freeman, 1997. An excellent introduction to what genes might have to do with behavior; written by a leader in the field. Includes the extraordinarily controversial subject of genetics and aggression.

Ridley, M. *Nature via Nurture: Genes, Experience, and What Makes Us Human*. New York: HarperCollins, 2003. An excellent introduction to the subject of macroevolution of genes and the regulation of gene expression by the environment.

———. *The Origins of Virtue: Human Instincts and the Evolution of Cooperation*. New York: Penguin Books, 1998. A good introduction to evolution and the neurobiology of behavior.

Sapolsky, R. *Monkeyluv and Other Essays on Our Lives as Animals*. New York: Scribner, 2005. By the course professor; contains further information about the neurobiology of our individual differences.

———. *The Trouble with Testosterone and Other Essays on the Biology of the Human Predicament*. New York: Scribner, 1997. By the course professor; contains further information about the neurobiology of our individual differences.

Squire, L. *Memory and Brain*. Oxford, U.K.: Oxford University Press, 1987. A good, although somewhat dated, introduction to the neurobiology of learning and memory, including long-term potentiation.

Whishaw, I., and B. Kolb. *Fundamentals of Human Neuropsychology*, 5th ed. New York: Worth Books, 2003. A review of the cognitive aspects of frontal function. Also covers the subject of the evolution of aggression and nonaggression.

Widmaier, E., H. Raff, and K. Strang. *Vander, Sherman, and Luciano's Human Physiology*, 9th ed. Boston, MA: McGraw Hill, 2004. A good, broad introduction to the nervous system.

Advanced Readings:

Cooper, J., F. Bloom, and R. Roth. *The Biochemical Basis of Neuropharmacology*, 8th ed. Oxford, U.K.: Oxford University Press, 2003. The best introductory book specifically about neurotransmission.

Gould, S. *The Structure of Evolutionary Theory*. Cambridge, MA: Harvard University Press, 2002. A massive overview of the idea of punctuated equilibrium.

Kandel, E., J. Schwartz, and T. Jessell. *The Foundations of Neural Science*, 4th ed. Boston, MA: McGraw Hill, 2000. The best (although quite advanced) textbook in the field of neurobiology.

Larsen, P., et al. *William's Textbook of Endocrinology*, 10th ed. Philadelphia: Saunders, 2003. The (very difficult) bible of the field of neuroendocrinology.

Nicholls, J., R. Martin, B. Wallace, and P. Fuchs. *From Neuron to Brain*, 4th ed. Sunderland, MA: Sinauer, 2001. A more advanced treatment of the nervous system.

Siegel, G., and B. Agranoff. *Basic Neurochemistry: Molecular, Cellular, and Medical Aspects*, 6th ed. Philadelphia: Lippincott-Raven, 1999. A more advanced text covering neurotransmission.

Squire, L. *Fundamental Neuroscience*, 2nd ed. London, U.K.: Academic Press, 2002. An excellent neuroscience textbook that covers long-term potentiation in some detail.

Watson, J., et al. *Molecular Biology of the Gene*, 5th ed. San Francisco: Pearson/Benjamin Cummings, 2004. A classic overview of how genes work by the co-discoverer of the structure of DNA.

Wilson, E. O. *Sociobiology: The New Synthesis, Twenty-fifth Anniversary Edition*. Cambridge, MA: Belknap Press, 2000. The most magisterial book on the subject of the evolution of behavior.

Internet Resources:

Harry Frank Guggenheim Foundation. <http://www.hfg.org/>. This organization funds research devoted to the understanding of violence. Once on the home page, click on "Search Research Reports."

International Brain Research Organization (IBRO). <http://www.iac-usnc.org/education.html>. This page contains several portals to lectures by leading neuroscientists. Some, however, are likely to be technical.

National Institute of Mental Health. <http://www.nimh.nih.gov/>. Home page for the main government branch devoted to research in mental health. There are numerous points on this home page that will gain entry to information relevant to this course.

Society for Neuroscience. <http://web.sfn.org>. Home page for the largest organization in the world devoted to the study of the brain. Once at the main site, click on “Public Resources.”